



熊猫集团



Shanghai Panda Group

上海熊猫机械(集团)有限公司

厂部地址: 上海市沪青平公路2599号

青浦工业园区熊猫高科技工业园

<http://www.panda.sh.cn>

电话: 021-59863888 59755522

传真: 021-59867777

邮编: 201704

明天会更好



本公司对产品具有改进权, 如有改动, 恕不通知

2011年3月印制

CK (R) 系列立式多级离心泵

CK(R) series vertical multi-stage centrifugal pump



上海熊猫机械(集团)有限公司

SHANGHAI PANDA MACHINE (GROUP) CO., LTD.

Shanghai Panda Shanghai Panda Shanghai Panda Shanghai Panda Shanghai Panda



公司简介

- 上海熊猫机械(集团)有限公司是上海市高新技术企业,是集水泵、成套设备的研发、生产、销售为一体的现代化大型企业集团,泵行业综合实力上海市排名第一,集团公司在全国拥有五大生产基地,下设38家分公司。是行业内拥有自主知识产权最多的企业,建筑楼宇用泵市场占有率位居全国第一!
- 集团主要生产水泵、无负压供水设备、智能化箱式泵站、中水处理设备、电气控制设备、成套供水设备、空压机、清洗机清洁机械设备等。年销售额2007年9.3亿元,2008年11.5亿元,2009年13.8亿元,其中出口额超1亿元。
- 集团公司以“节能、高效、环保、服务社会”为使命,不断进行技术创新,引进国际先进技术,提升产品的科技含量,成功研发了具有国际水准的系列产品;产品获得国家免检证书,是国家科技部、商务部,质检总局,环保总局联合认证并推广的国家重点新产品。是国家康居工程首选产品,被中国质量认证中心认定的新型节能产品,同时获国家专利150余项,多项产品填补了国内空白。其中4项专利产品入选《国家建筑标准设计图集》,6项专利产品是上海市高新技术成果转化项目,并在2009年负责起草《罐式管网叠压供水设备》、《箱式叠压给水设备》两项国家标准,其中《箱式叠压给水设备》已正式发布(标准号GB/T 24603-2009)。
- 公司拥有工业产品生产许可证,纯水生产许可证及各相关行业的进网许可证,并获得多项证书及荣誉:ISO9001-2000版国际质量认证、ISO14001-2004环境管理体系认证、CE认证、AAA资信等级、国家免检产品、国家节能产品认证、国家重点新产品、上海市高新技术企业、上海市先进企业、上海市名牌产品、上海市著名商标等。这是200多名技术人员及2800多名员工智慧的结晶。
- 公司产品使用于北京奥运会场馆、山东全运会场馆、上海世博会场馆、广州亚运会场馆等国家重点工程,广泛得到客户好评。
- 为满足客户的需求,真正落实“以客户需求为导向”的营销理念,公司在全国设立了8个营销分中心,并通过遍布全国的200多个办事处向客户提供着零距离的服务。
- 让我们共同为中国给排水超越国际先进水平做贡献!我们坚信“明天会更好”。

目录

总体数据

| | |
|-----------|-----|
| 性能范围 | 1 |
| 产品范围 | 1 |
| 应用 | 2 |
| 运行条件 | 2 |
| 型号含义 | 2 |
| 泵 | 2 |
| 电机 | 2 |
| 性能曲线说明 | 2 |
| 材料CK, CKR | 3-4 |
| 最大进口压力 | 5 |
| 最大工作压力 | 5 |
| 最小进口压力 | 6 |

技术数据

| | |
|-------------|-------|
| CK(R) 1s | 7-10 |
| CK(R) 1 | 11-14 |
| CK(R) 2 | 15-18 |
| CK(R) 3 | 19-22 |
| CK(R) 4 | 23-26 |
| CK(R) 5 | 27-30 |
| CK(R) 10 | 31-34 |
| CK(R) 15 | 35-38 |
| CK(R) 20 | 39-42 |
| 安装、使用注意事项 | 43 |
| 世博会项目部分用户名录 | 44 |





性能范围

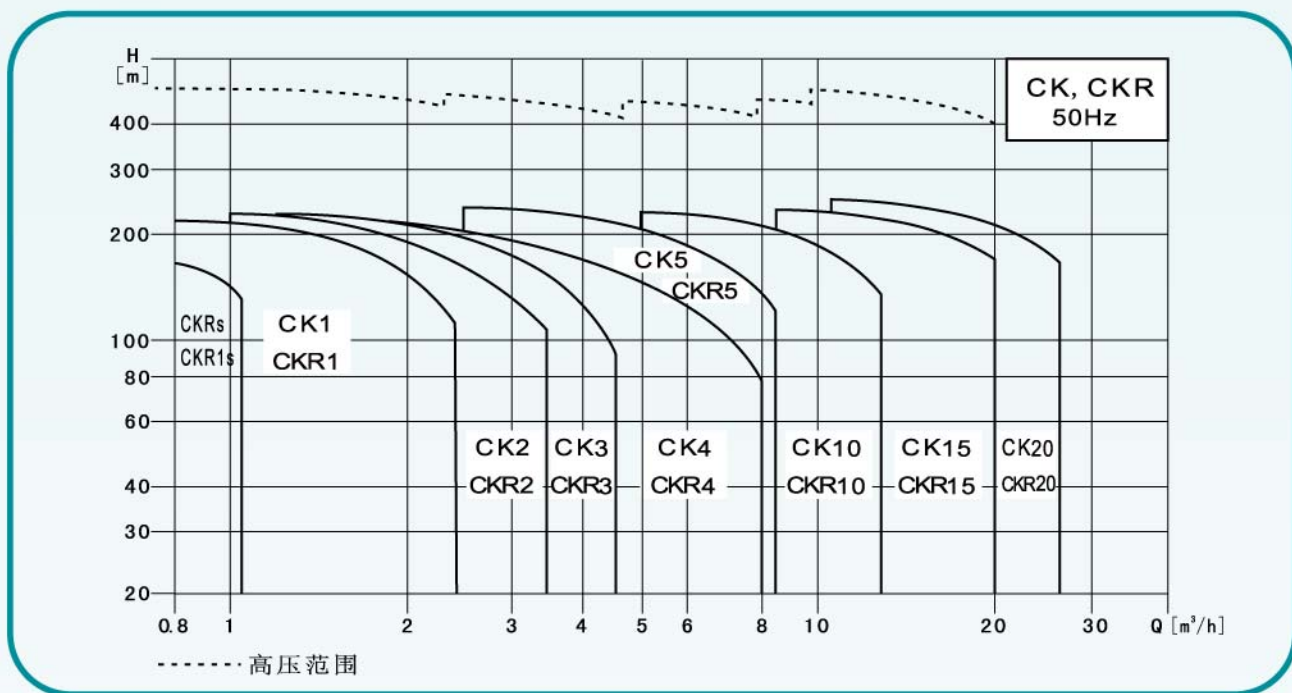

产品范围

| 说明 | CK(R)1s | CK(R)1 | CK(R)2 | CK(R)3 | CK(R)4 | CK(R)5 | CK(R)10 | CK(R)15 | CK(R)20 |
|-------------------------|-----------|-----------|-----------|-----------|----------|-----------|-----------|-----------|----------|
| 名义流量[m ³ /h] | 0.8 | 1 | 2 | 3 | 4 | 5 | 10 | 15 | 20 |
| 名义流量[L/s] | 0.28 | 0.28 | 0.56 | 0.83 | 1.1 | 1.39 | 2.8 | 4.17 | 5.56 |
| 流量范围[m ³ /h] | 0.3-1.1 | 0.7-2.4 | 1-3.5 | 1.2-4.5 | 1.5-8 | 2.5-8.5 | 5-14 | 8.5-23.5 | 10.5-29 |
| 流量范围[L/s] | 0.19-0.67 | 0.19-0.67 | 0.28-0.97 | 0.33-1.25 | 0.42-2.2 | 0.69-2.36 | 1.39-3.6 | 2.36-6.53 | 5-13 |
| 最大压力[bar] | 21 | 22 | 23 | 24 | 21 | 24 | 22 | 23 | 25 |
| 电机功率[kW] | 0.37-1.1 | 0.37-2.2 | 0.37-3 | 0.37-3 | 0.37-4 | 0.37-5.5 | 0.37-7.5 | 1.1-15 | 1.1-18.5 |
| 温度范围[°C] | -20~+120 | | -20~+120 | | | | | | |
| 最高效率[%] | 35 | 47 | 48 | 58 | 59 | 66 | 70 | 72 | 72 |
| 类型 | | | | | | | | | |
| CK | • | • | • | • | • | • | • | • | • |
| CKR | • | • | • | • | • | • | • | • | • |
| CK管路连接 | | | | | | | | | |
| DIN法兰 | DN25/DN32 | DN25/DN32 | DN25 | DN25/DN32 | DN25 | DN25/DN32 | DN40/DN50 | DN50 | DN50 |
| 椭圆法兰 | G1 | G1 | G1 | G1 | G1¼ | G1½ | G1½ | G2 | G2 |
| CKR管路连接 | | | | | | | | | |
| DIN法兰 | DN25 | DN25 | DN25 | DN25 | DN32 | DN32 | DN40 | DN50 | DN50 |

应用

CK/CKR是一种多功能产品，可以输送从自来水到工业液体的各种不同介质，适应于不同温度、流量和压力范围，CK适用于无腐蚀性液体，CKR适用于轻度腐蚀性液体。

- 供水：水厂过滤与输送，水厂分区送水、主管增压、高层建筑增压。
- 工业增压：流程水系统、清洗系统、高压冲洗系统、消防系统。
- 工业液体输送：冷却和空调系统、锅炉给水和冷凝系统、机床配套、酸和碱。
- 水处理：超滤系统、反渗透系统、蒸馏系统、分离器、游泳池。
- 灌溉：农田灌溉、喷灌、滴灌。

运行条件

- 稀薄、干净、非易燃易爆并不含固体颗粒或纤维
- 液体温度：常温型15℃至+70℃
热水型+70℃至+120℃
- 环境温度：最高+40℃
- 海拔：最高1000m

型号含义

CK(R)1s, 1, 2, 3, 4, 5, 10, 15, 20

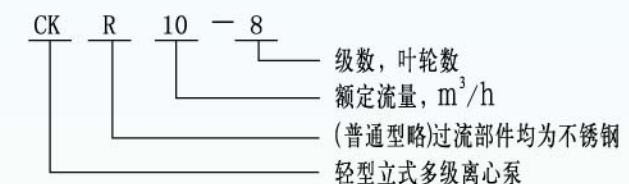

CK(R)20

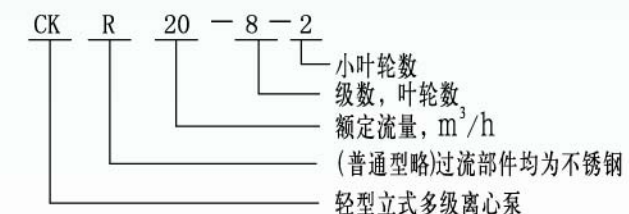

泵

CK和CKR泵是非自吸，立式多级离心泵。

泵由一泵基座和一泵头组成，流道腔组件和外筒体位于基座和泵头间由紧固螺栓紧固。泵的进出口位于基座上并在同一轴线上(管道式)。

所有泵均配一集装式免维护机械轴封。

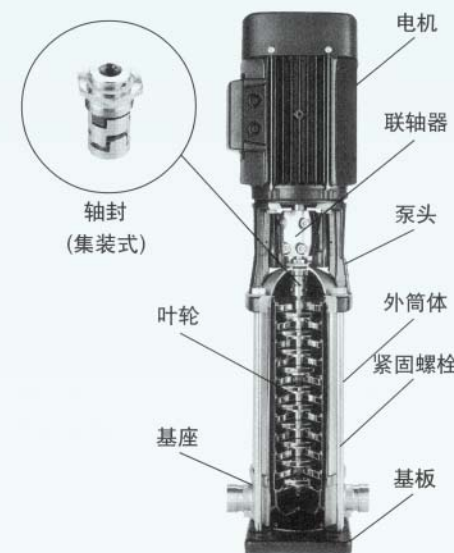

电机

- 电机为全封闭，风冷式二极标准电机。
- 防护等级：IP55
- 绝缘等级：F
- 标准电压：50Hz：1×220-230/240V
3×200-220/346-380V
3×220-240/380-415V
3×380-415V

性能曲线说明

下列说明适用于后面所示的曲线：

- 1、所有曲线都基于电机在恒速2900rpm的测量值。
- 2、曲线容差符合IS09906，附录A。
- 3、测试采用20℃不含空气的水，运动粘度为1mm²/s
- 4、泵的使用参照加粗曲线的性能范围，以防流量过小产生过热和流量过大使电机过载等。



CK1s CK1, CK2, CK3, CK4, CK5,
CK10, CK15, CK20



剖面图

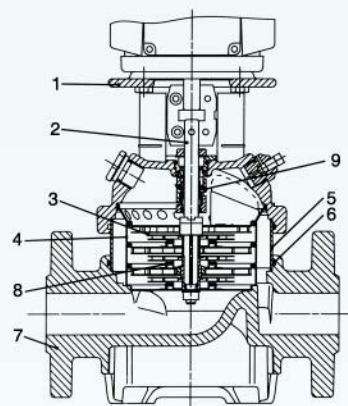

材料:

| 位置 | 名称 | 材料 | EN/DIN | AISI/ASTM |
|----|-----------|----------|------------|-----------|
| 1 | 泵头 | 铸铁 | EN-JL1030 | ASTM 25B |
| 2 | 轴 | 不锈钢 | 1.4301 | AISI 304 |
| 3 | 叶轮 | 不锈钢 | 1.4301 | AISI 304 |
| 4 | 腔体 | 不锈钢 | 1.4301 | AISI 304 |
| 5 | 外筒 | 不锈钢 | 1.4301 | AISI 304 |
| 6 | 外筒 O形圈 | EPDM或FKM | | |
| 7 | 基座 | 铸铁 | EN-JL 1030 | ASTM 25B |
| 8 | 颈环 | PTFE | | |
| 9 | 轴封 | 橡胶件 | | |
| | | EPDM或FKM | | |

CKR1s CKR1, CKR2, CKR3, CKR4, CKR5,
CKR10, CKR15, CKR20



剖面图

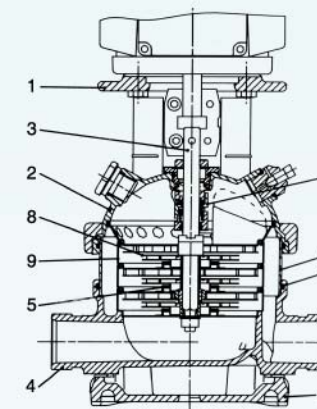

材料:

| 位置 | 名称 | 材料 | EN/DIN | AISI/ASTM |
|----|-----------|----------------|------------|-----------|
| 1 | 泵头 | 铸铁 | EN-JL1030 | ASTM 25B |
| 2 | 泵头盖 | 不锈钢 | 1.4301 | AISI304 |
| 3 | 轴 | 不锈钢 | 1.4301 | AISI304 |
| 4 | 基座 | 不锈钢 | 1.4301 | AISI304 |
| 5 | 颈环 | PTFE | | |
| 6 | 轴封 | Type cartridge | | |
| 7 | 基板 | 铸铁 | EN-JL 1030 | ASTM 25B |
| | 橡胶件 | EPDM或FKM | | |
| 8 | 叶轮 | 不锈钢 | 1.4301 | AISI 304 |
| 9 | 腔体 | 不锈钢 | 1.4301 | AISI 304 |
| 10 | 外筒 | 不锈钢 | 1.4301 | AISI 304 |
| 11 | 外筒 O形圈 | EPDM或FKM | | |



最大进口压力

下表为最大进口压力，但是实际的进口压力+泵闭阀压力必须低于允许工作压力。

| 型号 | 最大进口压力 |
|----------------------------------|------------------------------|
| CK(R)1s | |
| 1S-2 → 1S-36 | 10[bar] |
| CK(R)1 | |
| 1-2 → 1-36 | 10[bar] |
| CK(R)2 | |
| 2-2 2-3 → 2-11 2-13 → 2-26 | 6[bar] 10[bar] 15[bar] |
| CK(R)3 | |
| 3-2 → 3-29 3-31 → 3-36 | 10[bar] 15[bar] |
| CK(R)4 | |
| 4-2 4-3 → 4-10 4-13 → 4-22 | 6[bar] 10[bar] 15[bar] |
| CK(R)5 | |
| 5-2 → 5-16 5-18 → 5-36 | 10[bar] 15[bar] |
| CK(R)10 | |
| 10-1 → 10-6 10-7 → 10-22 | 8[bar] 10[bar] |
| CK(R)15 | |
| 15-1 → 15-3 15-4 → 15-17 | 8[bar] 10[bar] |
| CK(R)20 | |
| 20-1 → 20-3 20-4 → 20-17 | 8[bar] 10[bar] |

最大工作压力和温度范围

| 型号 | 椭圆法兰 | | PJE, Clamp, UNION, DIN | |
|--------------------|--------|-----------|------------------------|-----------|
| | 最大工作压力 | 液体温度范围 | 最大工作压力 | 液体温度范围 |
| CK(R)1s | 16bar | -20至+120℃ | 25bar | -20至+120℃ |
| CK(R)1 | 16bar | -20至+120℃ | 25bar | -20至+120℃ |
| CK(R)2 | 16bar | -20至+120℃ | 25bar | -20至+120℃ |
| CK(R)3 | 16bar | -20至+120℃ | 25bar | -20至+120℃ |
| CK(R)4 | 16bar | -20至+120℃ | 25bar | -20至+120℃ |
| CK(R)5 | 16bar | -20至+120℃ | 25bar | -20至+120℃ |
| CK(R)10-1 → 10-16 | 16bar | -20至+120℃ | 25bar | -20至+120℃ |
| CK(R)10-17 → 10-22 | - | - | 25bar | -20至+120℃ |
| CK(R)15-1 → 15-7 | 10bar | -20至+120℃ | - | - |
| CK(R)15-1 → 15-10 | - | - | 16bar | -20至+120℃ |
| CK(R)15-12 → 15-17 | - | - | 25bar | -20至+120℃ |
| CK(R)20-1 → 20-7 | 10bar | -20至+120℃ | - | - |
| CK(R)20-1 → 20-10 | - | - | 16bar | -20至+120℃ |
| CK(R)20-12 → 20-17 | - | - | 25bar | -20至+120℃ |

最小进口压力/NPSH

如果泵中的压力低于输送液体的蒸汽压力，可能发生气蚀，为避免气蚀，确保泵进口侧有一最小压力，最大吸程H[m]可按下式计算：

$$H_g = P_b \times 10.2 - NPSH - H_v - H_s$$

Pb=大气压力[bar]

(大气压力可设定为1bar)

在闭式系统中，Pb为系统压力[bar]

NPSH=净正吸头[m]

(可从NPSH曲线上泵可能的最大流量处读取)

Hf=入口的管路损失[m]

Hv=蒸汽压力[m]

Hs=安全余量 = 最小0.5m水头

如计算所得H为正值，泵可在最大吸程Hg情况下运行。

如计算所得H为负值，必须有一最小进口压力H水头。

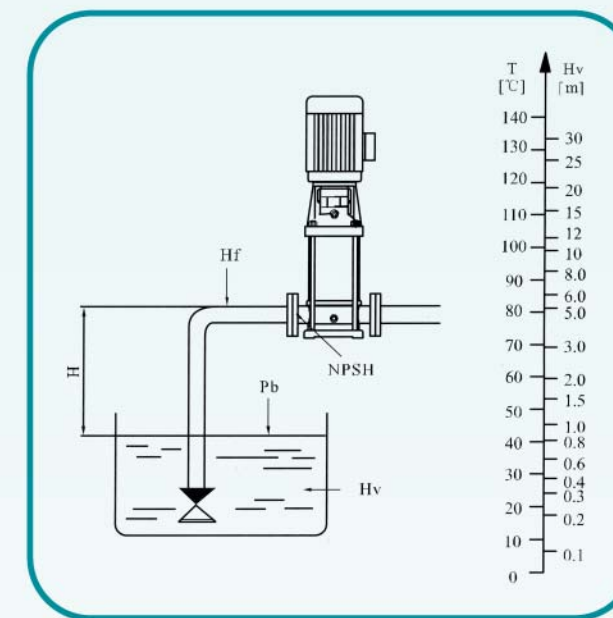

检查确保泵不会/没有处于气蚀状态

如何读取曲线图

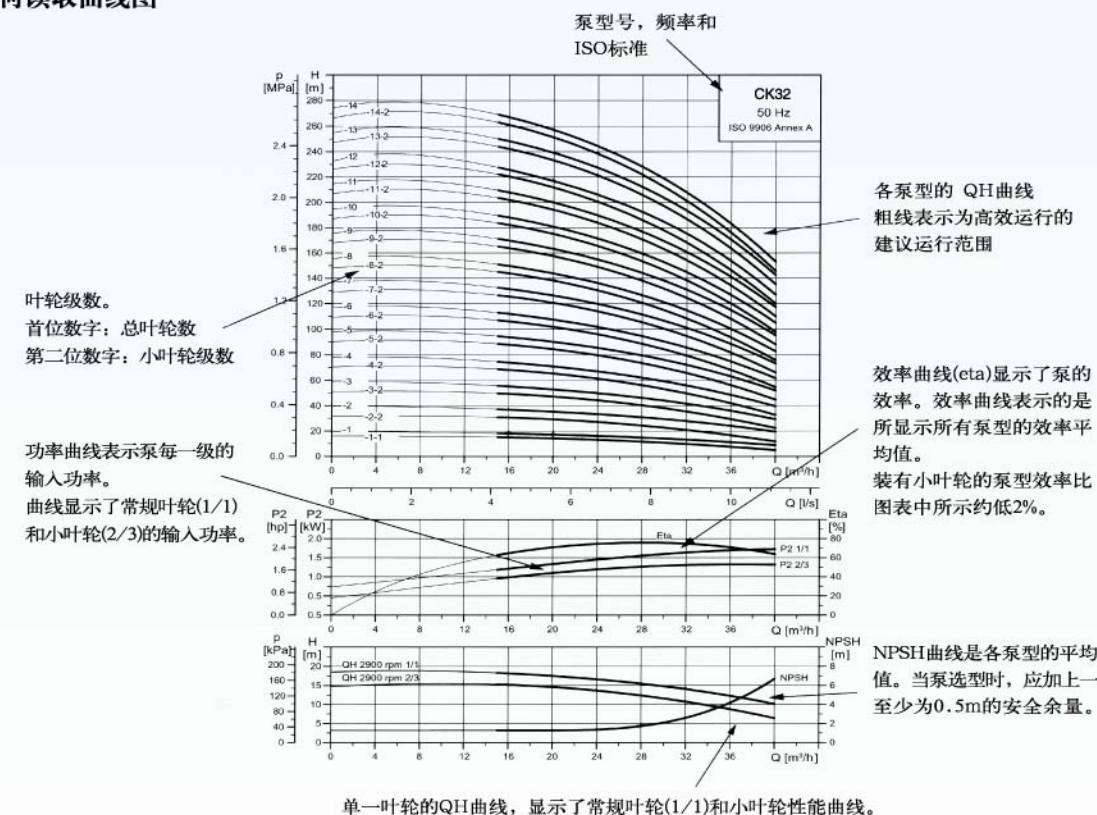



性能曲线

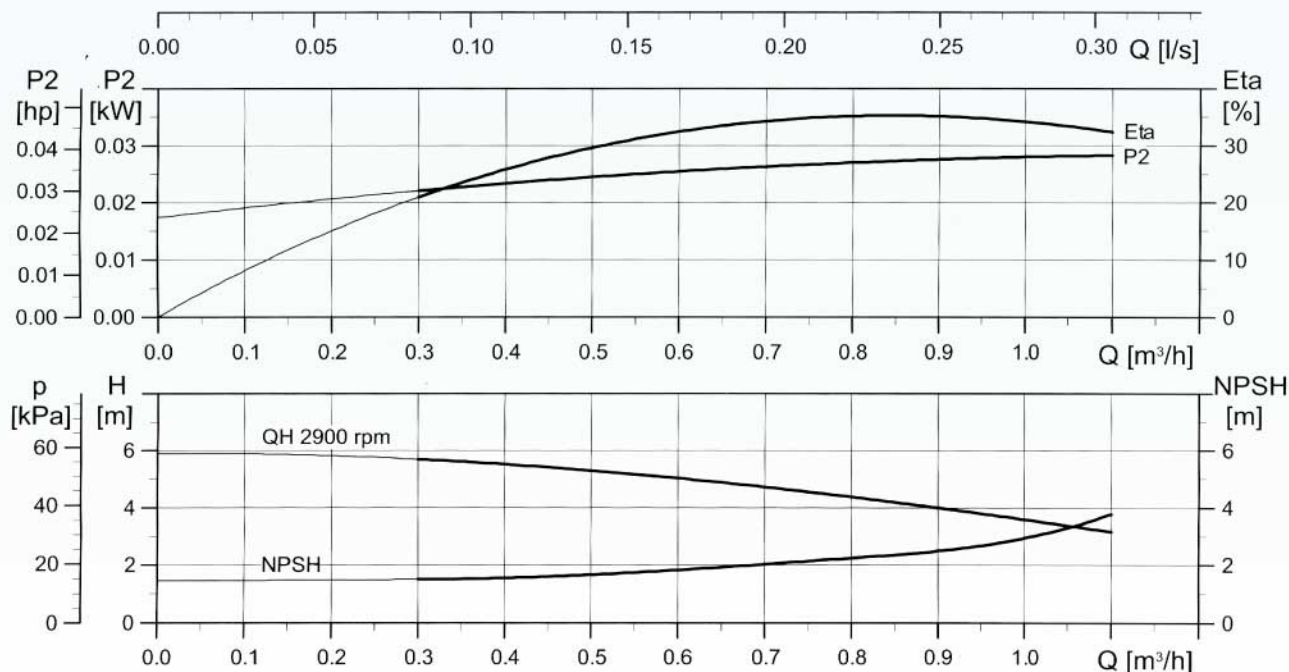
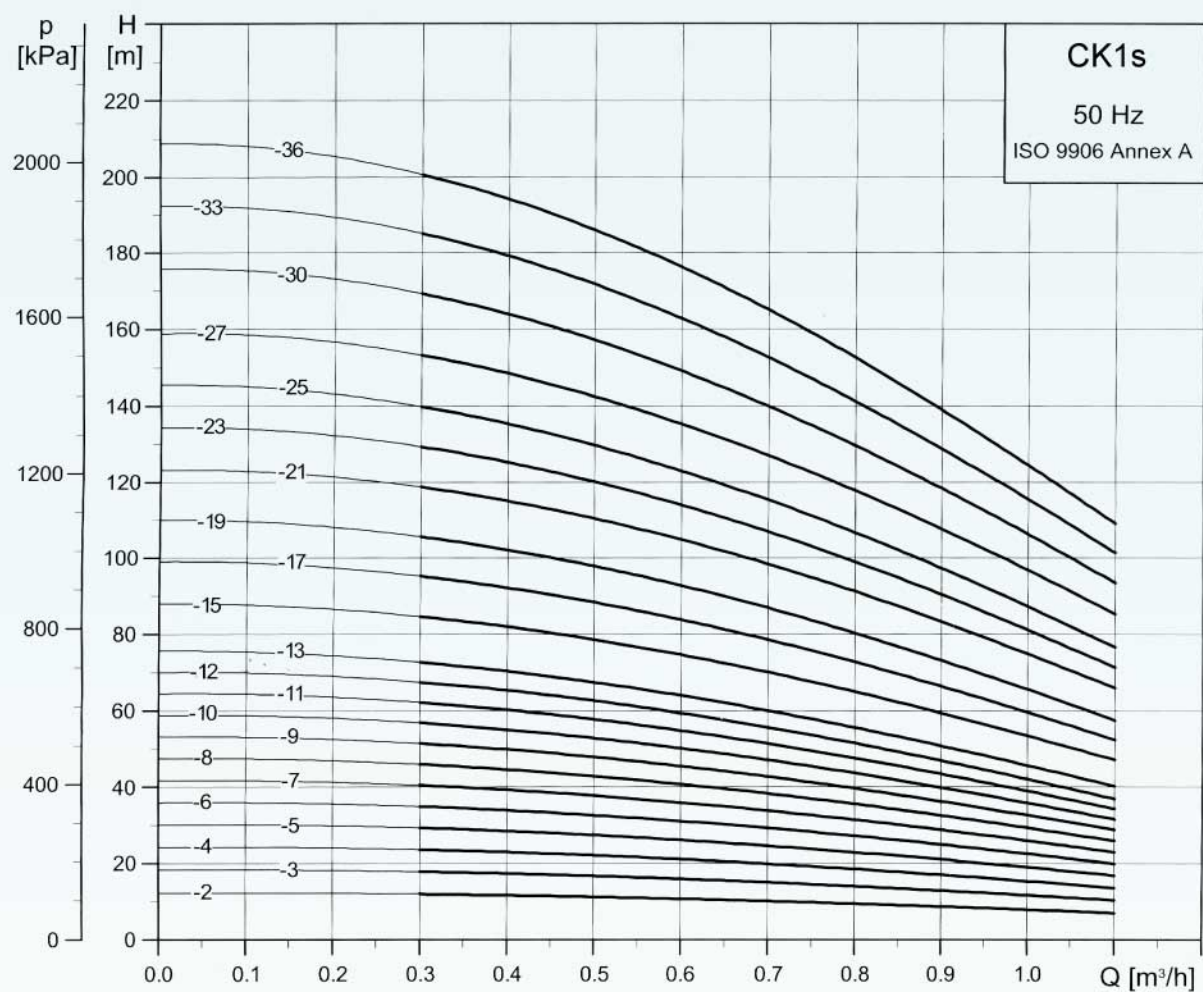

性能表

| 泵型号 | 电机 | | 流量 Q (n≈2900) | | | | | | | | | | |
|---------|------|------|---------------|-----|-----|-----|-----|-----|-----|-----|-----|-----|--|
| | kW | HP | m³/h | 0.3 | 0.4 | 0.5 | 0.6 | 0.7 | 0.8 | 0.9 | 1.0 | 1.1 | |
| CK1s-2 | 0.37 | 0.50 | 12 | 11 | 11 | 10 | 10 | 9 | 8 | 8 | 7 | 7 | |
| CK1s-3 | 0.37 | 0.50 | 18 | 17 | 16 | 16 | 15 | 14 | 13 | 12 | 10 | 10 | |
| CK1s-4 | 0.37 | 0.50 | 23 | 23 | 22 | 21 | 20 | 18 | 17 | 15 | 14 | 14 | |
| CK1s-5 | 0.37 | 0.50 | 29 | 28 | 27 | 26 | 24 | 23 | 21 | 19 | 16 | 16 | |
| CK1s-6 | 0.37 | 0.50 | 35 | 34 | 33 | 31 | 29 | 27 | 25 | 22 | 20 | 20 | |
| CK1s-7 | 0.37 | 0.50 | 40 | 39 | 38 | 36 | 34 | 31 | 29 | 26 | 23 | 23 | |
| CK1s-8 | 0.37 | 0.50 | 46 | 45 | 43 | 40 | 38 | 36 | 33 | 29 | 26 | 26 | |
| CK1s-9 | 0.37 | 0.50 | 51 | 50 | 48 | 45 | 43 | 40 | 36 | 32 | 29 | 29 | |
| CK1s-10 | 0.37 | 0.50 | 57 | 55 | 53 | 50 | 47 | 44 | 40 | 36 | 32 | 32 | |
| CK1s-11 | 0.37 | 0.50 | 62 | 60 | 59 | 55 | 51 | 48 | 44 | 39 | 35 | 35 | |
| CK1s-12 | 0.37 | 0.50 | 66 | 65 | 62 | 60 | 55 | 52 | 47 | 42 | 37 | 37 | |
| CK1s-13 | 0.37 | 0.50 | 73 | 70 | 67 | 64 | 60 | 55 | 51 | 46 | 40 | 40 | |
| CK1s-15 | 0.55 | 0.75 | 84 | 82 | 78 | 75 | 70 | 65 | 60 | 54 | 48 | 48 | |
| CK1s-17 | 0.55 | 0.75 | 95 | 92 | 88 | 84 | 78 | 73 | 66 | 60 | 52 | 52 | |
| CK1s-19 | 0.55 | 0.75 | 106 | 102 | 98 | 93 | 87 | 80 | 73 | 66 | 58 | 58 | |
| CK1s-21 | 0.75 | 1.0 | 119 | 115 | 110 | 105 | 98 | 91 | 84 | 75 | 66 | 66 | |
| CK1s-23 | 0.75 | 1.0 | 129 | 125 | 120 | 114 | 107 | 99 | 90 | 82 | 72 | 72 | |
| CK1s-25 | 0.75 | 1.0 | 140 | 135 | 130 | 123 | 115 | 107 | 97 | 87 | 77 | 77 | |
| CK1s-27 | 1.1 | 1.5 | 153 | 148 | 142 | 135 | 127 | 118 | 107 | 96 | 86 | 86 | |
| CK1s-30 | 1.1 | 1.5 | 169 | 164 | 157 | 147 | 140 | 129 | 118 | 107 | 94 | 94 | |
| CK1s-33 | 1.1 | 1.5 | 185 | 179 | 171 | 163 | 152 | 141 | 128 | 116 | 103 | 103 | |
| CK1s-36 | 1.1 | 1.5 | 201 | 194 | 186 | 176 | 165 | 153 | 139 | 125 | 110 | 110 | |

安装图

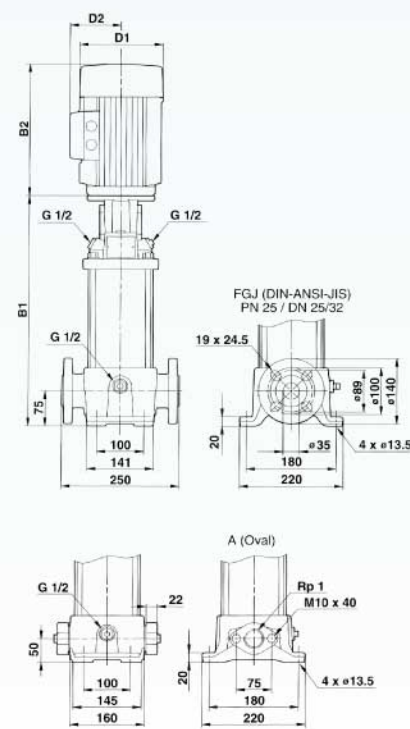

尺寸和重量

| 泵型号 | 尺寸 [mm] | | | | 净重 [kg] | |
|---------|---------|------------|-----------|--------------|---------|-----------|
| | 椭圆法兰 B1 | 椭圆法兰 B1+B2 | DIN 法兰 B1 | DIN 法兰 B1+B2 | 椭圆法兰 D1 | DIN 法兰 D2 |
| CK1s-2 | 254 | 445 | 279 | 470 | 141 | 109 |
| CK1s-3 | 254 | 445 | 279 | 470 | 141 | 109 |
| CK1s-4 | 272 | 463 | 297 | 488 | 141 | 109 |
| CK1s-5 | 290 | 481 | 315 | 506 | 141 | 109 |
| CK1s-6 | 308 | 499 | 333 | 524 | 141 | 109 |
| CK1s-7 | 326 | 517 | 351 | 542 | 141 | 109 |
| CK1s-8 | 344 | 535 | 369 | 560 | 141 | 109 |
| CK1s-9 | 362 | 553 | 387 | 578 | 141 | 109 |
| CK1s-10 | 380 | 571 | 405 | 596 | 141 | 109 |
| CK1s-11 | 398 | 589 | 423 | 614 | 141 | 109 |
| CK1s-12 | 416 | 607 | 441 | 632 | 141 | 109 |
| CK1s-13 | 434 | 625 | 459 | 650 | 141 | 109 |
| CK1s-15 | 470 | 661 | 495 | 686 | 141 | 109 |
| CK1s-17 | 506 | 697 | 531 | 722 | 141 | 109 |
| CK1s-19 | 542 | 733 | 567 | 758 | 141 | 109 |
| CK1s-21 | 584 | 815 | 609 | 840 | 141 | 109 |
| CK1s-23 | 620 | 851 | 645 | 876 | 141 | 109 |
| CK1s-25 | 656 | 887 | 681 | 912 | 178 | 109 |
| CK1s-27 | 692 | 923 | 717 | 948 | 178 | 109 |
| CK1s-30 | - | - | 771 | 1002 | 178 | 109 |
| CK1s-33 | - | - | 825 | 1056 | 178 | 109 |
| CK1s-36 | - | - | 879 | 1110 | 178 | 109 |



性能曲线

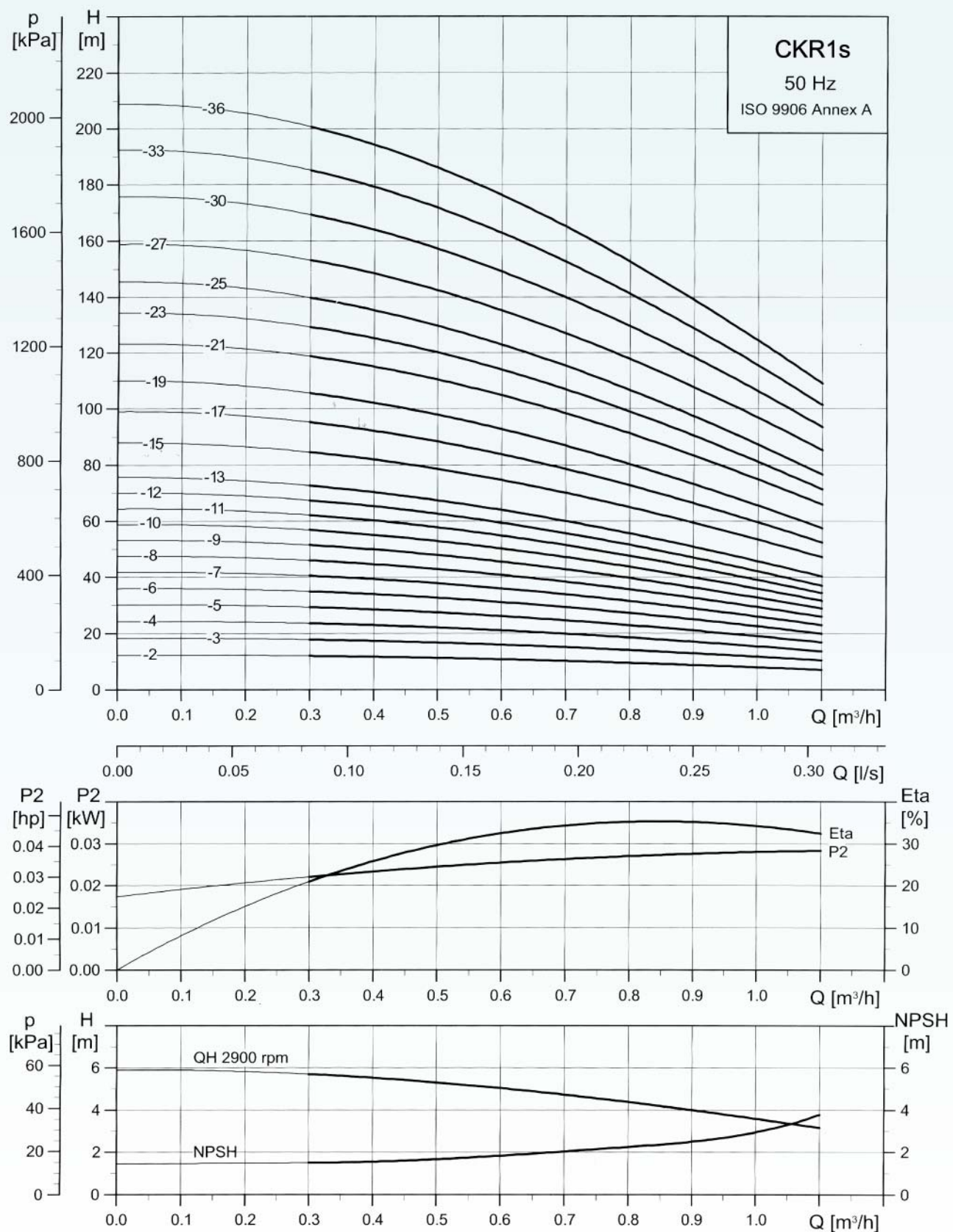

性能表

| 泵型号 | 电机 | | 流量 Q (n≈2900) | | | | | | | | | | |
|----------|------|------|---------------|-----|-----|-----|-----|-----|-----|-----|-----|-----|--|
| | kW | HP | m³/h | 0.3 | 0.4 | 0.5 | 0.6 | 0.7 | 0.8 | 0.9 | 1.0 | 1.1 | |
| CKR1s-2 | 0.37 | 0.50 | 12 | 11 | 11 | 10 | 10 | 9 | 8 | 8 | 7 | | |
| CKR1s-3 | 0.37 | 0.50 | 18 | 17 | 16 | 16 | 15 | 14 | 13 | 12 | 10 | | |
| CKR1s-4 | 0.37 | 0.50 | 23 | 23 | 22 | 21 | 20 | 18 | 17 | 15 | 14 | | |
| CKR1s-5 | 0.37 | 0.50 | 29 | 28 | 27 | 26 | 24 | 23 | 21 | 19 | 16 | | |
| CKR1s-6 | 0.37 | 0.50 | 35 | 34 | 33 | 31 | 29 | 27 | 25 | 22 | 20 | | |
| CKR1s-7 | 0.37 | 0.50 | 40 | 39 | 38 | 36 | 34 | 31 | 29 | 26 | 23 | | |
| CKR1s-8 | 0.37 | 0.50 | 46 | 45 | 43 | 40 | 38 | 36 | 33 | 29 | 26 | | |
| CKR1s-9 | 0.37 | 0.50 | 51 | 50 | 48 | 45 | 43 | 40 | 36 | 32 | 29 | | |
| CKR1s-10 | 0.37 | 0.50 | 57 | 55 | 53 | 50 | 47 | 44 | 40 | 36 | 32 | | |
| CKR1s-11 | 0.37 | 0.50 | 62 | 60 | 59 | 55 | 51 | 48 | 44 | 39 | 35 | | |
| CKR1s-12 | 0.37 | 0.50 | 66 | 65 | 62 | 60 | 55 | 52 | 47 | 42 | 37 | | |
| CKR1s-13 | 0.37 | 0.50 | 73 | 70 | 67 | 64 | 60 | 55 | 51 | 46 | 40 | | |
| CKR1s-15 | 0.55 | 0.75 | 84 | 82 | 78 | 75 | 70 | 65 | 60 | 54 | 48 | | |
| CKR1s-17 | 0.55 | 0.75 | 95 | 92 | 88 | 84 | 78 | 73 | 66 | 60 | 52 | | |
| CKR1s-19 | 0.55 | 0.75 | 106 | 102 | 98 | 93 | 87 | 80 | 73 | 66 | 58 | | |
| CKR1s-21 | 0.75 | 1.0 | 119 | 115 | 110 | 105 | 98 | 91 | 84 | 75 | 66 | | |
| CKR1s-23 | 0.75 | 1.0 | 129 | 125 | 120 | 114 | 107 | 99 | 90 | 82 | 72 | | |
| CKR1s-25 | 0.75 | 1.0 | 140 | 135 | 130 | 123 | 115 | 107 | 97 | 87 | 77 | | |
| CKR1s-27 | 1.1 | 1.5 | 153 | 148 | 142 | 135 | 127 | 118 | 107 | 96 | 86 | | |
| CKR1s-30 | 1.1 | 1.5 | 169 | 164 | 157 | 147 | 140 | 129 | 118 | 107 | 94 | | |
| CKR1s-33 | 1.1 | 1.5 | 185 | 179 | 171 | 163 | 152 | 141 | 128 | 116 | 103 | | |
| CKR1s-36 | 1.1 | 1.5 | 201 | 194 | 186 | 176 | 165 | 153 | 139 | 125 | 110 | | |

安装图

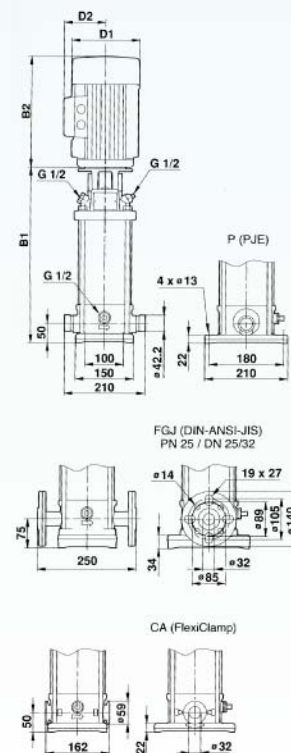

尺寸和重量

| 泵型号 | 尺寸[mm] | | | | 净重[kg] | | | |
|----------|--------|-------|--------|-------|--------|--------|----|----|
| | PJE/CA | | DIN 法兰 | | PJE/CA | DIN 法兰 | | |
| CKR1s-2 | B1 | B1+B2 | B1 | B1+B2 | D1 | D2 | 16 | 20 |
| CKR1s-3 | 257 | 448 | 282 | 473 | 141 | 109 | 16 | 21 |
| CKR1s-4 | 275 | 466 | 300 | 491 | 141 | 109 | 17 | 21 |
| CKR1s-5 | 293 | 484 | 318 | 509 | 141 | 109 | 17 | 21 |
| CKR1s-6 | 311 | 502 | 336 | 527 | 141 | 109 | 18 | 22 |
| CKR1s-7 | 329 | 520 | 354 | 545 | 141 | 109 | 18 | 22 |
| CKR1s-8 | 347 | 538 | 372 | 563 | 141 | 109 | 19 | 23 |
| CKR1s-9 | 365 | 556 | 390 | 581 | 141 | 109 | 20 | 23 |
| CKR1s-10 | 383 | 574 | 408 | 599 | 141 | 109 | 20 | 23 |
| CKR1s-11 | 401 | 592 | 426 | 617 | 141 | 109 | 20 | 24 |
| CKR1s-12 | 419 | 610 | 444 | 635 | 141 | 109 | 20 | 24 |
| CKR1s-13 | 437 | 628 | 462 | 653 | 141 | 109 | 20 | 25 |
| CKR1s-15 | 473 | 664 | 498 | 689 | 141 | 109 | 22 | 26 |
| CKR1s-17 | 509 | 700 | 534 | 725 | 141 | 109 | 23 | 27 |
| CKR1s-19 | 545 | 736 | 570 | 761 | 141 | 109 | 23 | 28 |
| CKR1s-21 | 587 | 818 | 612 | 843 | 141 | 109 | 26 | 31 |
| CKR1s-23 | 623 | 854 | 648 | 879 | 141 | 109 | 27 | 31 |
| CKR1s-25 | 659 | 890 | 684 | 915 | 141 | 109 | 28 | 32 |
| CKR1s-27 | 749 | 926 | 720 | 951 | 141 | 109 | 31 | 35 |
| CKR1s-30 | 765 | 980 | 774 | 1005 | 141 | 109 | 32 | 36 |
| CKR1s-33 | 803 | 1034 | 828 | 1059 | 141 | 109 | 33 | 37 |
| CKR1s-36 | 857 | 1088 | 882 | 1113 | 141 | 109 | 34 | 39 |



性能曲线

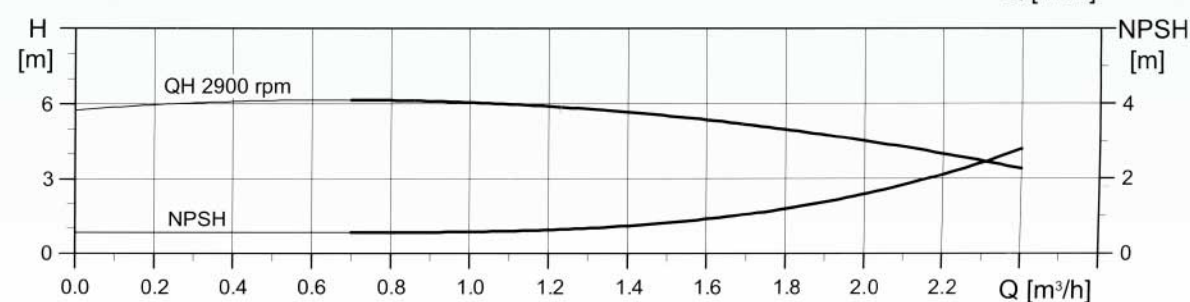
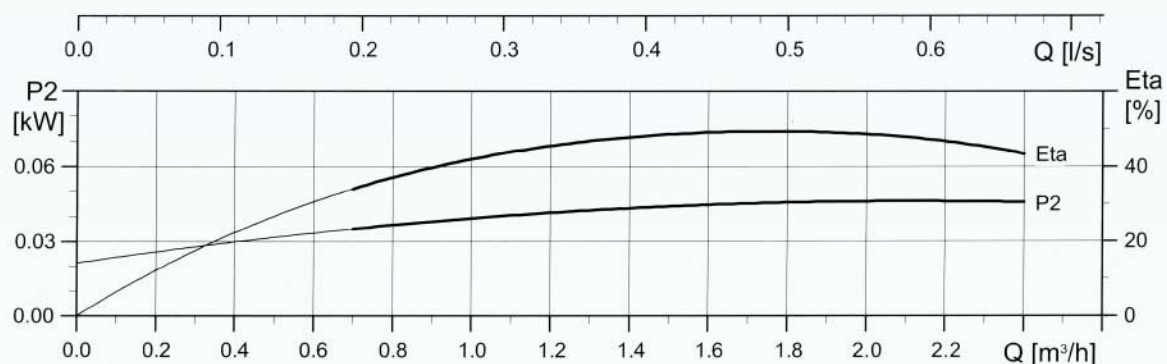
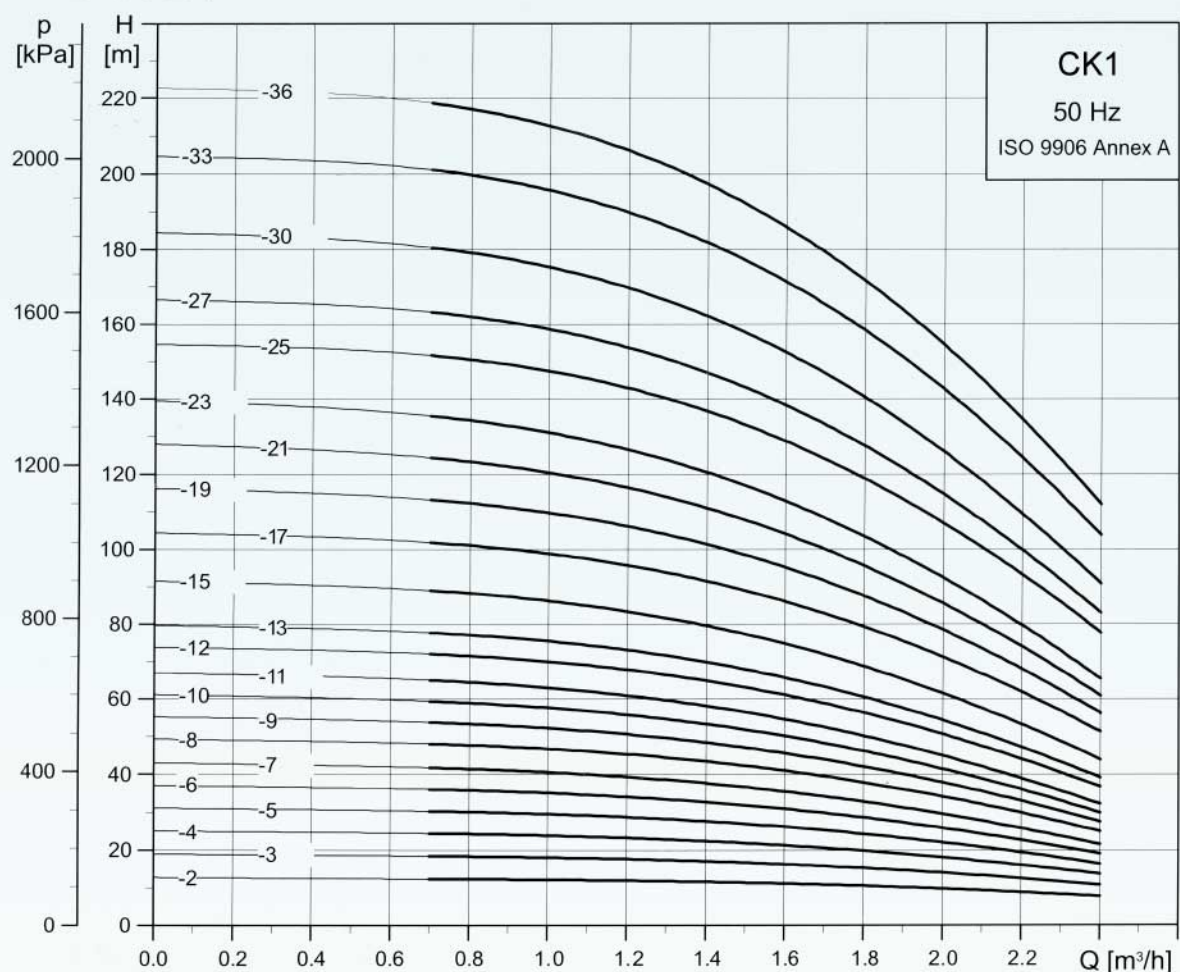

性能表

| 泵型号 | 电机 | | 流量 Q (n≈2900) | | | | | | | | | |
|--------|------|------|---------------|------|-----|------|-----|-----|-----|-----|-----|-----|
| | kW | HP | m³/h | 0.7 | 1.0 | 1.2 | 1.4 | 1.6 | 1.8 | 2.0 | 2.2 | 2.4 |
| CK1-2 | 0.37 | 0.50 | 13 | 12.5 | 12 | 11.5 | 11 | 10 | 9 | 8 | 7 | |
| CK1-3 | 0.37 | 0.50 | 18 | 17 | 16 | 15 | 14 | 13 | 12 | 11 | 10 | |
| CK1-4 | 0.37 | 0.50 | 25 | 24 | 23 | 22 | 21 | 20 | 18 | 16 | 14 | |
| CK1-5 | 0.37 | 0.50 | 30 | 29 | 28 | 27 | 26 | 25 | 22 | 19 | 17 | |
| CK1-6 | 0.37 | 0.50 | 36 | 35 | 34 | 33 | 32 | 29 | 26 | 23 | 19 | |
| CK1-7 | 0.37 | 0.50 | 42 | 41 | 39 | 37 | 35 | 32 | 30 | 26 | 22 | |
| CK1-8 | 0.55 | 0.75 | 48 | 47 | 46 | 43 | 41 | 38 | 34 | 30 | 25 | |
| CK1-9 | 0.55 | 0.75 | 54 | 53 | 52 | 49 | 46 | 43 | 38 | 33 | 28 | |
| CK1-10 | 0.55 | 0.75 | 59 | 57 | 55 | 52 | 50 | 47 | 43 | 37 | 30 | |
| CK1-11 | 0.55 | 0.75 | 65 | 63 | 61 | 58 | 54 | 50 | 46 | 39 | 32 | |
| CK1-12 | 0.75 | 1.0 | 71 | 69 | 67 | 64 | 61 | 56 | 50 | 45 | 36 | |
| CK1-13 | 0.75 | 1.0 | 77 | 75 | 73 | 70 | 66 | 61 | 54 | 48 | 39 | |
| CK1-15 | 0.75 | 1.0 | 89 | 87 | 85 | 80 | 74 | 69 | 62 | 54 | 45 | |
| CK1-17 | 1.1 | 1.5 | 102 | 99 | 96 | 91 | 86 | 79 | 71 | 62 | 52 | |
| CK1-19 | 1.1 | 1.5 | 113 | 110 | 107 | 102 | 95 | 88 | 78 | 68 | 57 | |
| CK1-21 | 1.1 | 1.5 | 124 | 121 | 117 | 112 | 105 | 95 | 86 | 74 | 61 | |
| CK1-23 | 1.1 | 1.5 | 135 | 132 | 127 | 121 | 112 | 104 | 93 | 80 | 66 | |
| CK1-25 | 1.5 | 2.0 | 151 | 148 | 144 | 137 | 129 | 119 | 107 | 92 | 78 | |
| CK1-27 | 1.5 | 2.0 | 163 | 159 | 153 | 146 | 138 | 128 | 114 | 100 | 83 | |
| CK1-30 | 1.5 | 2.0 | 181 | 176 | 170 | 162 | 152 | 140 | 127 | 110 | 91 | |
| CK1-33 | 2.2 | 3.0 | 202 | 196 | 190 | 182 | 171 | 158 | 143 | 124 | 104 | |
| CK1-36 | 2.2 | 3.0 | 218 | 213 | 207 | 198 | 187 | 172 | 154 | 134 | 112 | |

安装图

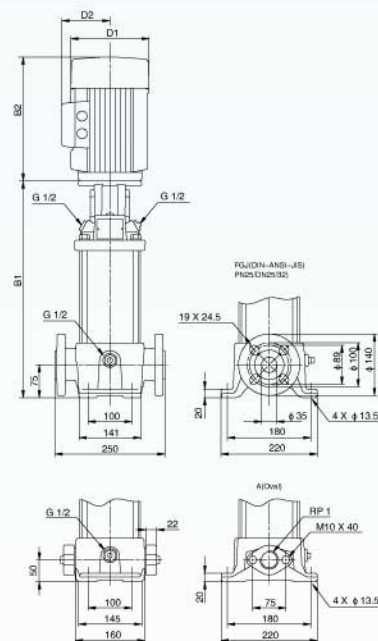

尺寸和重量

| 泵型号 | 尺寸[mm] | | | | 净重[kg] | |
|--------|--------|-------|--------|-------|--------|--------|
| | 椭圆法兰 | | DIN 法兰 | | 椭圆法兰 | DIN 法兰 |
| | B1 | B1+B2 | B1 | B1+B2 | D1 | D2 |
| CK1-2 | 254 | 445 | 279 | 470 | 141 | 109 |
| CK1-3 | 254 | 445 | 279 | 470 | 141 | 109 |
| CK1-4 | 272 | 463 | 297 | 488 | 141 | 109 |
| CK1-5 | 290 | 481 | 315 | 506 | 141 | 109 |
| CK1-6 | 308 | 499 | 333 | 524 | 141 | 109 |
| CK1-7 | 326 | 517 | 351 | 542 | 141 | 109 |
| CK1-8 | 344 | 535 | 369 | 560 | 141 | 109 |
| CK1-9 | 362 | 553 | 387 | 578 | 141 | 109 |
| CK1-10 | 380 | 571 | 405 | 596 | 141 | 109 |
| CK1-11 | 398 | 589 | 423 | 614 | 141 | 109 |
| CK1-12 | 422 | 653 | 447 | 678 | 141 | 109 |
| CK1-13 | 440 | 671 | 465 | 696 | 141 | 109 |
| CK1-15 | 476 | 707 | 501 | 732 | 141 | 109 |
| CK1-17 | 512 | 743 | 537 | 768 | 141 | 109 |
| CK1-19 | 548 | 779 | 573 | 804 | 141 | 109 |
| CK1-21 | 584 | 815 | 609 | 840 | 141 | 109 |
| CK1-23 | 620 | 851 | 645 | 876 | 141 | 109 |
| CK1-25 | - | - | 697 | 978 | 178 | 110 |
| CK1-27 | - | - | 733 | 1014 | 178 | 110 |
| CK1-30 | - | - | 787 | 1068 | 178 | 110 |
| CK1-33 | - | - | 841 | 1162 | 178 | 110 |
| CK1-36 | - | - | 895 | 1216 | 178 | 110 |



性能曲线

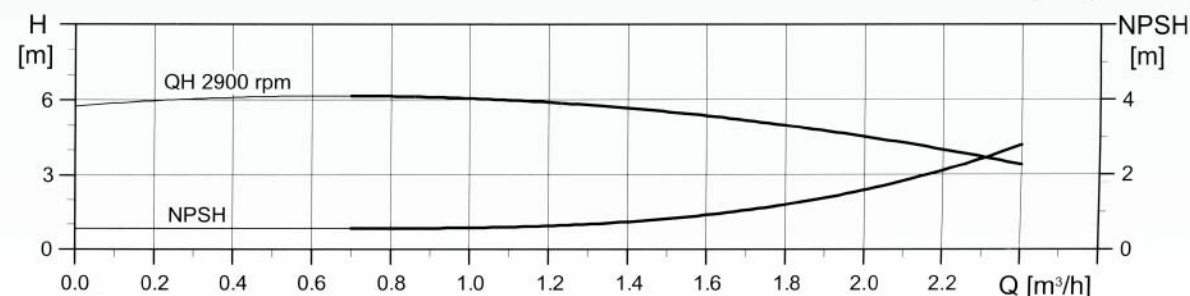
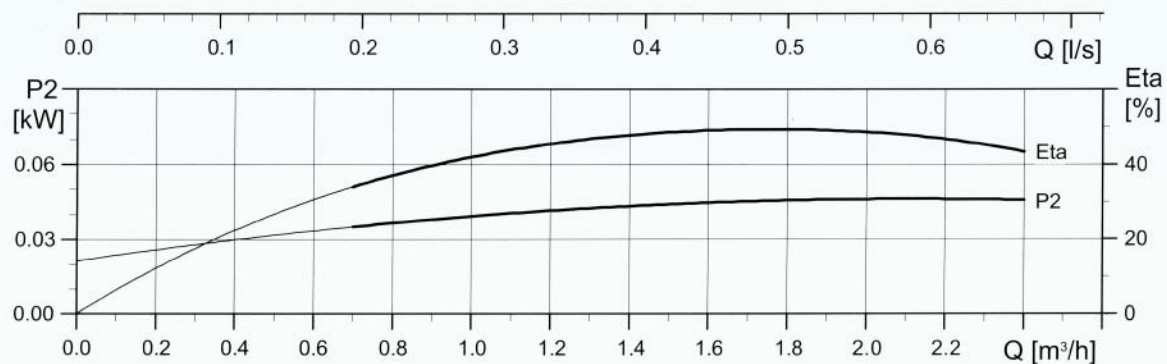
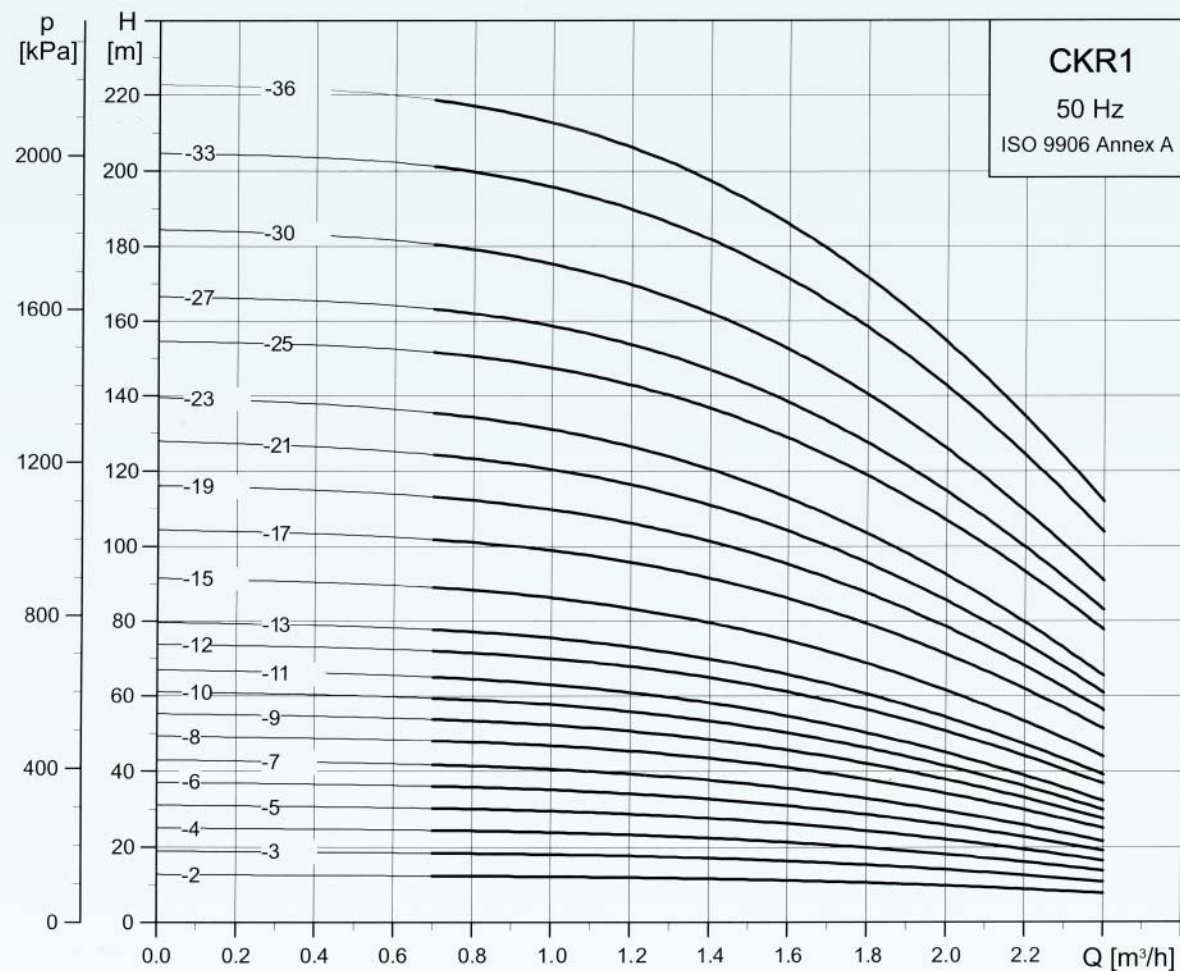

性能表

| 泵型号 | 电机 | | 流量 Q (n≈2900) | | | | | | | | | |
|---------|------|------|---------------|------|-----|------|-----|-----|-----|-----|-----|-----|
| | kW | HP | m³/h | 0.7 | 1.0 | 1.2 | 1.4 | 1.6 | 1.8 | 2.0 | 2.2 | 2.4 |
| CKR1-2 | 0.37 | 0.50 | 13 | 12.5 | 12 | 11.5 | 11 | 10 | 9 | 8 | 7 | |
| CKR1-3 | 0.37 | 0.50 | 18 | 17 | 16 | 15 | 14 | 13 | 12 | 11 | 10 | |
| CKR1-4 | 0.37 | 0.50 | 25 | 24 | 23 | 22 | 21 | 20 | 18 | 16 | 14 | |
| CKR1-5 | 0.37 | 0.50 | 30 | 29 | 28 | 27 | 26 | 25 | 22 | 19 | 17 | |
| CKR1-6 | 0.37 | 0.50 | 36 | 35 | 34 | 33 | 32 | 29 | 26 | 23 | 19 | |
| CKR1-7 | 0.37 | 0.50 | 42 | 41 | 39 | 37 | 35 | 32 | 30 | 26 | 22 | |
| CKR1-8 | 0.55 | 0.75 | 48 | 47 | 46 | 43 | 41 | 38 | 34 | 30 | 25 | |
| CKR1-9 | 0.55 | 0.75 | 54 | 53 | 52 | 49 | 46 | 43 | 38 | 33 | 28 | |
| CKR1-10 | 0.55 | 0.75 | 59 | 57 | 55 | 52 | 50 | 47 | 43 | 37 | 30 | |
| CKR1-11 | 0.55 | 0.75 | 65 | 63 | 61 | 58 | 54 | 50 | 46 | 39 | 32 | |
| CKR1-12 | 0.75 | 1.0 | 71 | 69 | 67 | 64 | 61 | 56 | 50 | 45 | 36 | |
| CKR1-13 | 0.75 | 1.0 | 77 | 75 | 73 | 70 | 66 | 61 | 54 | 48 | 39 | |
| CKR1-15 | 0.75 | 1.0 | 89 | 87 | 85 | 80 | 74 | 69 | 62 | 54 | 45 | |
| CKR1-17 | 1.1 | 1.5 | 102 | 99 | 96 | 91 | 86 | 79 | 71 | 62 | 52 | |
| CKR1-19 | 1.1 | 1.5 | 113 | 110 | 107 | 102 | 95 | 88 | 78 | 68 | 57 | |
| CKR1-21 | 1.1 | 1.5 | 124 | 121 | 117 | 112 | 105 | 95 | 86 | 74 | 61 | |
| CKR1-23 | 1.1 | 1.5 | 135 | 132 | 127 | 121 | 112 | 104 | 93 | 80 | 66 | |
| CKR1-25 | 1.5 | 2.0 | 151 | 148 | 144 | 137 | 129 | 119 | 107 | 92 | 78 | |
| CKR1-27 | 1.5 | 2.0 | 163 | 159 | 153 | 146 | 138 | 128 | 114 | 100 | 83 | |
| CKR1-30 | 1.5 | 2.0 | 181 | 176 | 170 | 162 | 152 | 140 | 127 | 110 | 91 | |
| CKR1-33 | 2.2 | 3.0 | 202 | 196 | 190 | 182 | 171 | 158 | 143 | 124 | 104 | |
| CKR1-36 | 2.2 | 3.0 | 218 | 213 | 207 | 198 | 187 | 172 | 154 | 134 | 112 | |

安装图

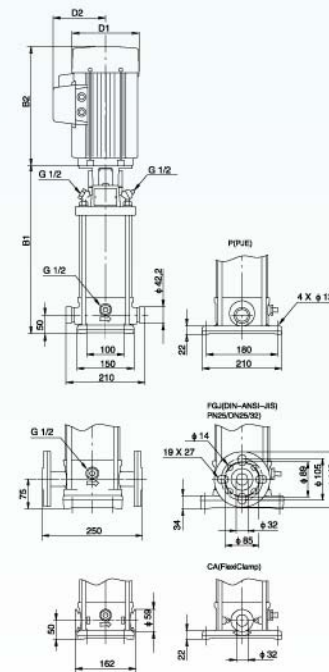

尺寸和重量

| 泵型号 | 尺寸[mm] | | | | 净重[kg] | | | |
|---------|--------|-------|--------|-------|--------|-----|--------|--------|
| | PJE/CA | | DIN 法兰 | | D1 | D2 | PJE/CA | DIN 法兰 |
| | B1 | B1+B2 | B1 | B1+B2 | | | | |
| CKR1-2 | 257 | 448 | 282 | 473 | 141 | 109 | 16 | 20 |
| CKR1-3 | 257 | 448 | 282 | 473 | 141 | 109 | 16 | 21 |
| CKR1-4 | 275 | 466 | 300 | 491 | 141 | 109 | 17 | 21 |
| CKR1-5 | 293 | 484 | 318 | 509 | 141 | 109 | 17 | 21 |
| CKR1-6 | 311 | 502 | 336 | 527 | 141 | 109 | 18 | 22 |
| CKR1-7 | 329 | 520 | 354 | 545 | 141 | 109 | 18 | 22 |
| CKR1-8 | 347 | 538 | 372 | 563 | 141 | 109 | 19 | 23 |
| CKR1-9 | 365 | 556 | 390 | 581 | 141 | 109 | 20 | 24 |
| CKR1-10 | 383 | 574 | 408 | 599 | 141 | 109 | 20 | 24 |
| CKR1-11 | 401 | 592 | 426 | 617 | 141 | 109 | 20 | 24 |
| CKR1-12 | 425 | 656 | 450 | 681 | 141 | 109 | 23 | 27 |
| CKR1-13 | 443 | 674 | 468 | 699 | 141 | 109 | 23 | 28 |
| CKR1-15 | 479 | 710 | 504 | 735 | 141 | 109 | 24 | 28 |
| CKR1-17 | 515 | 746 | 540 | 771 | 141 | 109 | 27 | 31 |
| CKR1-19 | 551 | 782 | 576 | 807 | 141 | 109 | 28 | 32 |
| CKR1-21 | 587 | 818 | 612 | 843 | 141 | 109 | 29 | 33 |
| CKR1-23 | 623 | 854 | 648 | 879 | 141 | 109 | 30 | 34 |
| CKR1-25 | 675 | 956 | 700 | 981 | 178 | 110 | 37 | 41 |
| CKR1-27 | 711 | 992 | 736 | 1017 | 178 | 110 | 38 | 42 |
| CKR1-30 | 765 | 1046 | 790 | 1071 | 178 | 110 | 39 | 43 |
| CKR1-33 | 819 | 1140 | 844 | 1165 | 178 | 110 | 41 | 45 |
| CKR1-36 | 873 | 1194 | 898 | 1219 | 178 | 110 | 42 | 46 |



性能曲线

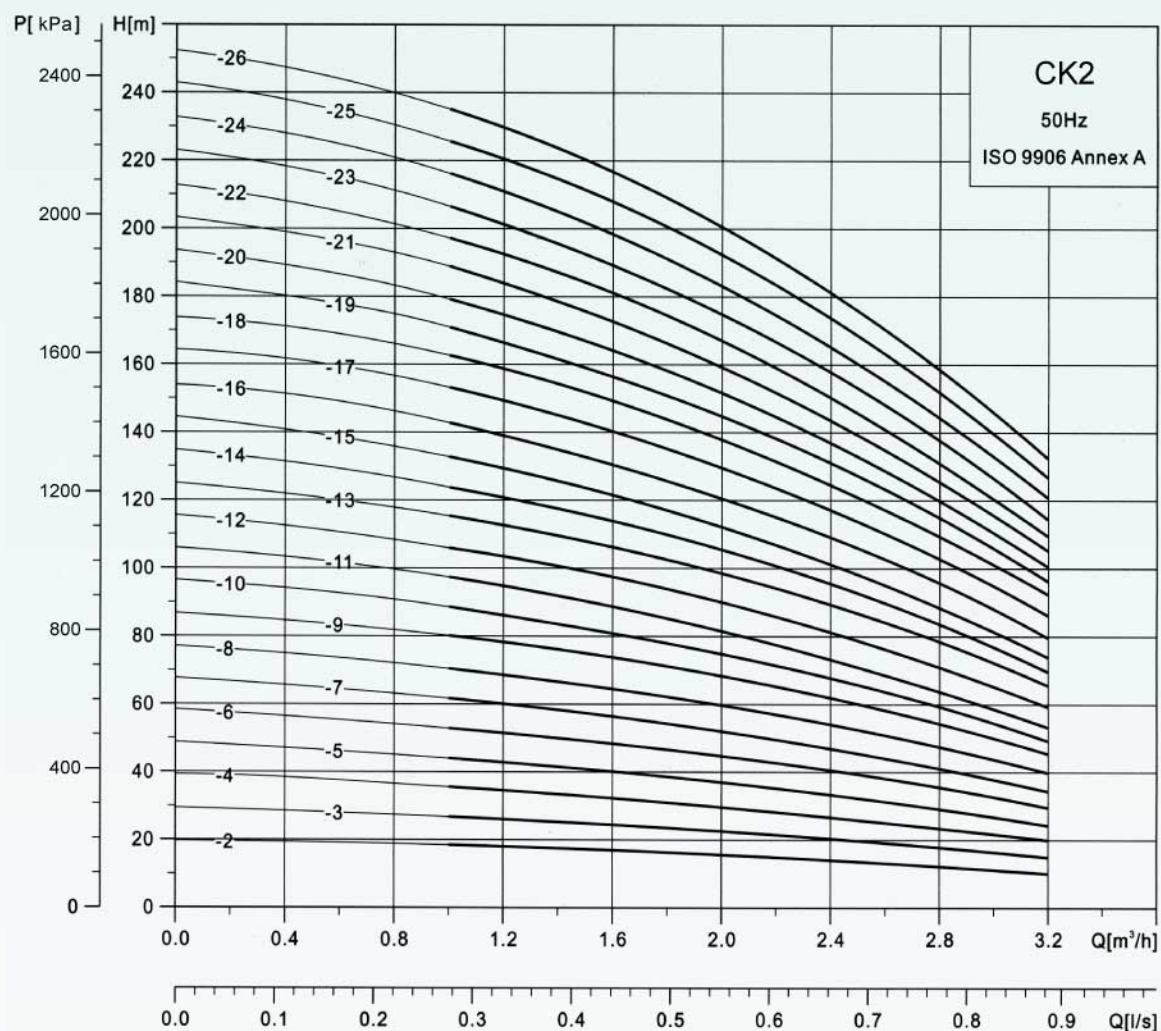

CK2
50Hz
ISO 9906 Annex A

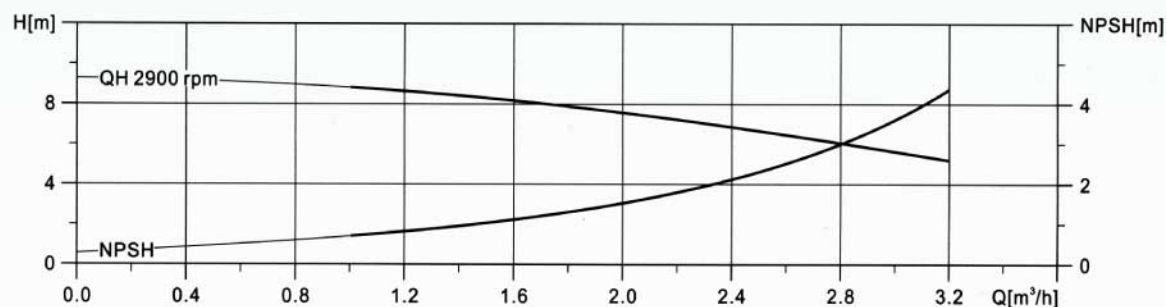
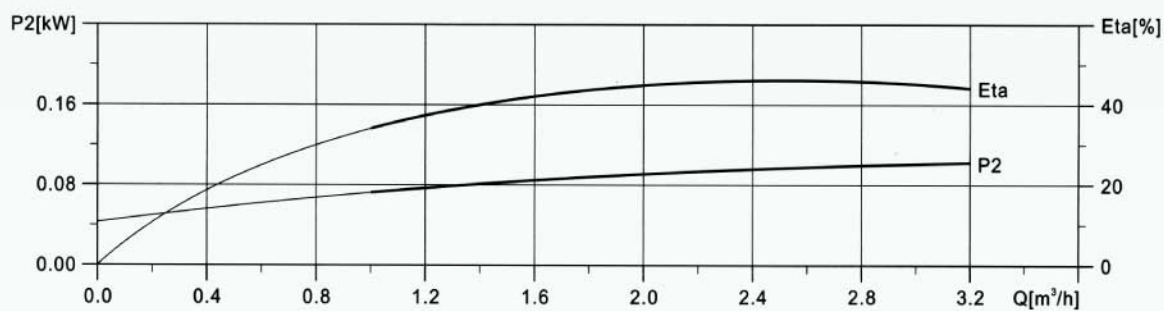

性能表

| 泵型号 | 电机 | | 流量 Q (n≈2900) | | | | | | | |
|--------|------|------|---------------|-----|-----|-----|-----|-----|-----|-----|
| | kW | HP | m³/h l/s | 1.0 | 1.2 | 1.6 | 2.0 | 2.4 | 2.8 | 3.2 |
| CK2-2 | 0.37 | 0.50 | 18 | 17 | 16 | 15 | 14 | 12 | 10 | |
| CK2-3 | 0.37 | 0.50 | 27 | 26 | 24 | 22 | 20 | 18 | 15 | |
| CK2-4 | 0.55 | 0.75 | 36 | 35 | 33 | 30 | 26 | 24 | 17 | |
| CK2-5 | 0.55 | 0.75 | 45 | 43 | 40 | 37 | 33 | 30 | 24 | |
| CK2-6 | 0.75 | 1.0 | 53 | 52 | 50 | 45 | 40 | 36 | 30 | |
| CK2-7 | 0.75 | 1.0 | 63 | 61 | 57 | 52 | 47 | 41 | 35 | |
| CK2-8 | 1.1 | 1.5 | 71 | 69 | 65 | 59 | 54 | 47 | 40 | |
| CK2-9 | 1.1 | 1.5 | 80 | 78 | 73 | 67 | 61 | 54 | 45 | |
| CK2-10 | 1.1 | 1.5 | 89 | 86 | 81 | 74 | 67 | 59 | 49 | |
| CK2-11 | 1.1 | 1.5 | 98 | 95 | 89 | 82 | 73 | 64 | 54 | |
| CK2-12 | 1.5 | 2.0 | 107 | 103 | 97 | 90 | 81 | 71 | 59 | |
| CK2-13 | 1.5 | 2.0 | 116 | 114 | 106 | 98 | 89 | 78 | 65 | |
| CK2-14 | 1.5 | 2.0 | 125 | 122 | 114 | 105 | 94 | 84 | 69 | |
| CK2-15 | 1.5 | 2.0 | 134 | 130 | 123 | 112 | 100 | 90 | 73 | |
| CK2-16 | 2.2 | 3.0 | 143 | 139 | 131 | 120 | 107 | 96 | 80 | |
| CK2-17 | 2.2 | 3.0 | 152 | 148 | 139 | 128 | 114 | 102 | 86 | |
| CK2-18 | 2.2 | 3.0 | 161 | 157 | 148 | 136 | 121 | 108 | 91 | |
| CK2-19 | 2.2 | 3.0 | 170 | 165 | 156 | 143 | 127 | 113 | 95 | |
| CK2-20 | 2.2 | 3.0 | 179 | 174 | 164 | 150 | 134 | 119 | 100 | |
| CK2-21 | 2.2 | 3.0 | 188 | 183 | 172 | 157 | 141 | 124 | 105 | |
| CK2-22 | 2.2 | 3.0 | 197 | 192 | 180 | 165 | 148 | 130 | 110 | |
| CK2-23 | 3.0 | 4.0 | 205 | 201 | 188 | 173 | 155 | 137 | 115 | |
| CK2-24 | 3.0 | 4.0 | 214 | 210 | 197 | 181 | 163 | 144 | 120 | |
| CK2-25 | 3.0 | 4.0 | 225 | 219 | 205 | 189 | 170 | 151 | 127 | |
| CK2-26 | 3.0 | 4.0 | 234 | 228 | 214 | 198 | 178 | 158 | 132 | |

安装图

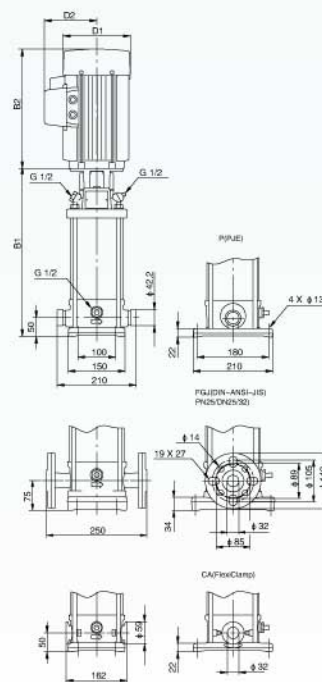

尺寸和重量

| 泵型号 | 尺寸[mm] | | | | 净重[kg] | | | |
|--------|--------|-----|--------|------|--------|-----|------|--------|
| | 椭圆法兰 | | DIN 法兰 | | D1 | D2 | 椭圆法兰 | DIN 法兰 |
| B1 | B1+B2 | B1 | B1+B2 | 法兰 | | | 法兰 | |
| CK2-2 | 254 | 445 | 279 | 470 | 141 | 109 | 18 | 23 |
| CK2-3 | 254 | 445 | 279 | 470 | 141 | 109 | 18 | 23 |
| CK2-4 | 272 | 463 | 297 | 488 | 141 | 109 | 19 | 23 |
| CK2-5 | 290 | 481 | 315 | 506 | 141 | 109 | 19 | 24 |
| CK2-6 | 314 | 545 | 339 | 570 | 141 | 109 | 20 | 24 |
| CK2-7 | 332 | 563 | 357 | 588 | 141 | 109 | 20 | 25 |
| CK2-8 | 350 | 581 | 375 | 606 | 141 | 109 | 21 | 26 |
| CK2-9 | 368 | 599 | 393 | 624 | 141 | 109 | 21 | 26 |
| CK2-10 | 386 | 617 | 401 | 642 | 141 | 109 | 22 | 26 |
| CK2-11 | 404 | 635 | 429 | 660 | 141 | 109 | 22 | 27 |
| CK2-12 | 438 | 719 | 463 | 744 | 178 | 110 | 24 | 29 |
| CK2-13 | 456 | 737 | 481 | 762 | 178 | 110 | 25 | 29 |
| CK2-14 | 474 | 755 | 499 | 780 | 178 | 110 | 26 | 30 |
| CK2-15 | 492 | 773 | 417 | 798 | 178 | 110 | 26 | 30 |
| CK2-16 | 510 | 791 | 535 | 816 | 178 | 110 | 28 | 32 |
| CK2-17 | 528 | 809 | 553 | 834 | 178 | 110 | 29 | 33 |
| CK2-18 | 546 | 827 | 571 | 852 | 178 | 110 | 29 | 34 |
| CK2-19 | 564 | 845 | 589 | 870 | 178 | 110 | 29 | 34 |
| CK2-20 | 582 | 863 | 607 | 888 | 178 | 110 | 30 | 35 |
| CK2-21 | 600 | 881 | 625 | 906 | 178 | 110 | 30 | 35 |
| CK2-22 | 618 | 899 | 643 | 924 | 178 | 110 | 30 | 36 |
| CK2-23 | 640 | 975 | 665 | 1000 | 198 | 120 | 31 | 36 |
| CK2-24 | - | - | 683 | 1018 | 198 | 120 | - | 40 |
| CK2-25 | - | - | 701 | 1036 | 198 | 120 | - | 44 |
| CK2-26 | - | - | 719 | 1054 | 198 | 120 | - | 45 |



性能曲线

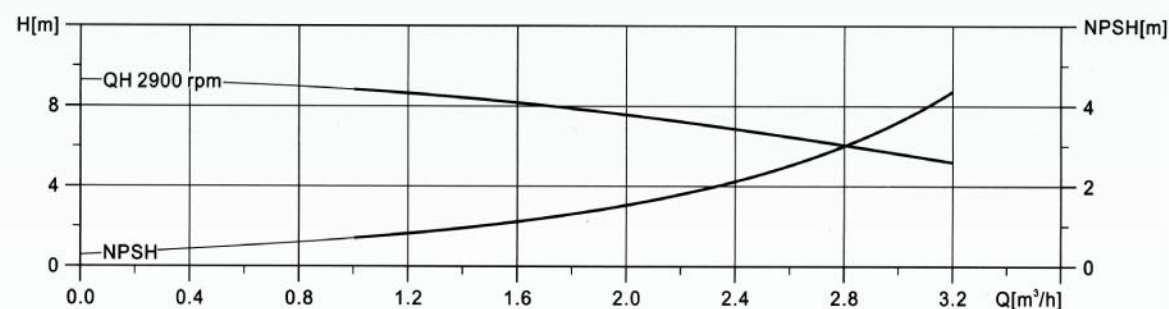
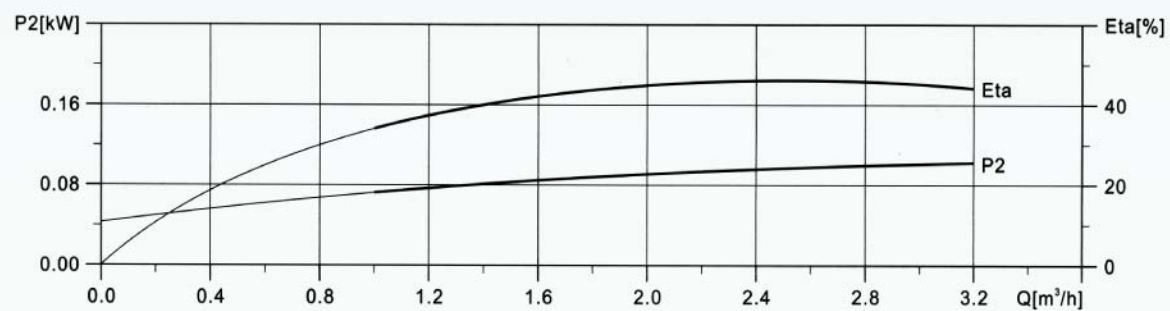
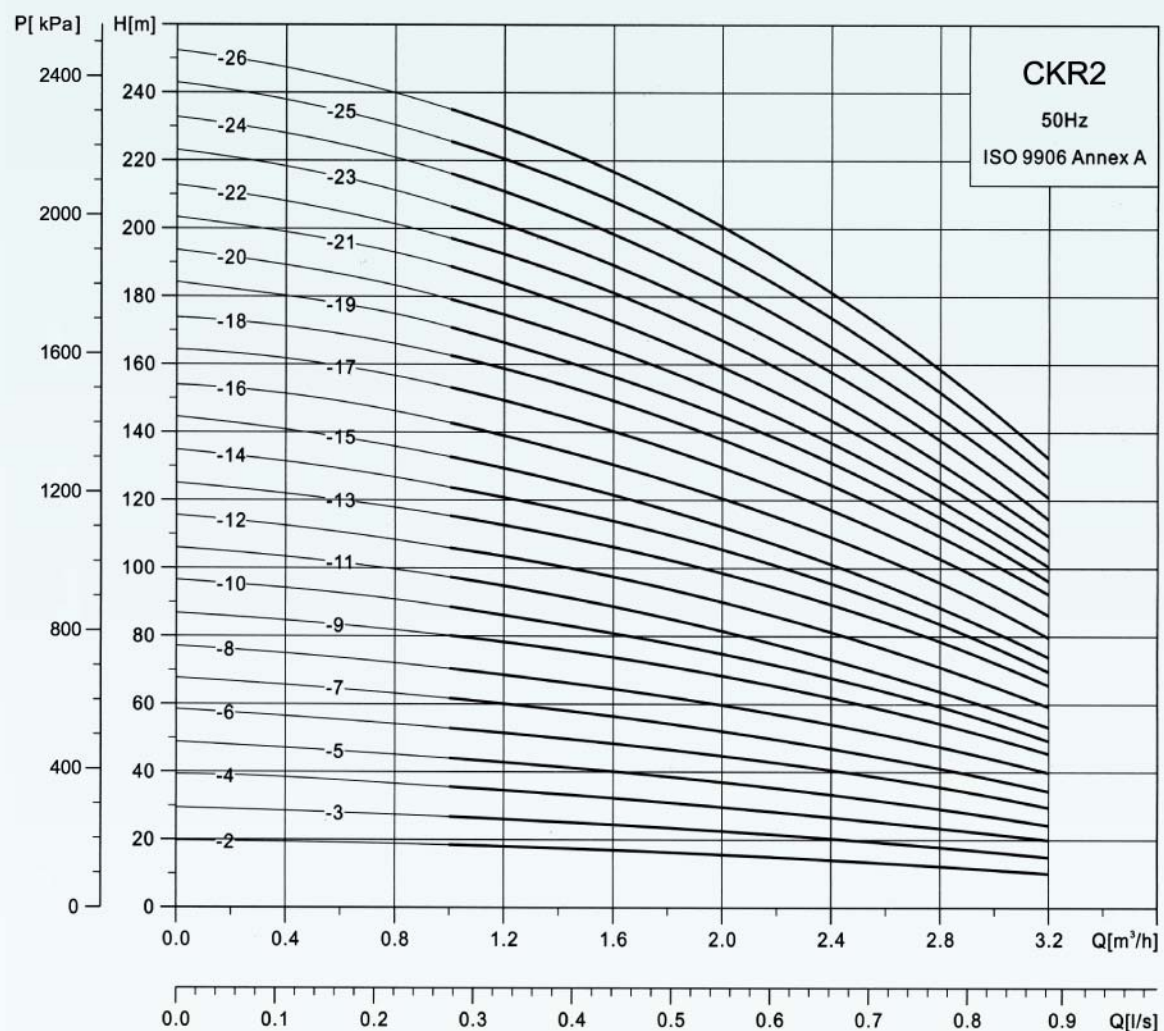

性能表

| 泵型号 | 电机 | | 流量 Q (n≈2900) | | | | | | | |
|---------|------|------|---------------|-----|-----|-----|-----|-----|-----|-----|
| | kW | HP | m³/h l/s | 1.0 | 1.2 | 1.6 | 2.0 | 2.4 | 2.8 | 3.2 |
| CKR2-2 | 0.37 | 0.50 | 18 | 17 | 16 | 15 | 14 | 12 | 10 | |
| CKR2-3 | 0.37 | 0.50 | 27 | 26 | 24 | 22 | 20 | 18 | 15 | |
| CKR2-4 | 0.55 | 0.75 | 36 | 35 | 33 | 30 | 26 | 24 | 17 | |
| CKR2-5 | 0.55 | 0.75 | 45 | 43 | 40 | 37 | 33 | 30 | 24 | |
| CKR2-6 | 0.75 | 1.0 | 53 | 52 | 50 | 45 | 40 | 36 | 30 | |
| CKR2-7 | 0.75 | 1.0 | 63 | 61 | 57 | 52 | 47 | 41 | 35 | |
| CKR2-8 | 1.1 | 1.5 | 71 | 69 | 65 | 59 | 54 | 47 | 40 | |
| CKR2-9 | 1.1 | 1.5 | 80 | 78 | 73 | 67 | 61 | 54 | 45 | |
| CKR2-10 | 1.1 | 1.5 | 89 | 86 | 81 | 74 | 67 | 59 | 49 | |
| CKR2-11 | 1.1 | 1.5 | 98 | 95 | 89 | 82 | 73 | 64 | 54 | |
| CKR2-12 | 1.5 | 2.0 | 107 | 103 | 97 | 90 | 81 | 71 | 59 | |
| CKR2-13 | 1.5 | 2.0 | 116 | 114 | 106 | 98 | 89 | 78 | 65 | |
| CKR2-14 | 1.5 | 2.0 | 125 | 122 | 114 | 105 | 94 | 84 | 69 | |
| CKR2-15 | 1.5 | 2.0 | 134 | 130 | 123 | 112 | 100 | 90 | 73 | |
| CKR2-16 | 2.2 | 3.0 | 143 | 139 | 131 | 120 | 107 | 96 | 80 | |
| CKR2-17 | 2.2 | 3.0 | 152 | 148 | 139 | 128 | 114 | 102 | 86 | |
| CKR2-18 | 2.2 | 3.0 | 161 | 157 | 148 | 136 | 121 | 108 | 91 | |
| CKR2-19 | 2.2 | 3.0 | 170 | 165 | 156 | 143 | 127 | 113 | 95 | |
| CKR2-20 | 2.2 | 3.0 | 179 | 174 | 164 | 150 | 134 | 119 | 100 | |
| CKR2-21 | 2.2 | 3.0 | 188 | 183 | 172 | 157 | 141 | 124 | 105 | |
| CKR2-22 | 2.2 | 3.0 | 197 | 192 | 180 | 165 | 148 | 130 | 110 | |
| CKR2-23 | 3.0 | 4.0 | 205 | 201 | 188 | 173 | 155 | 137 | 115 | |
| CKR2-24 | 3.0 | 4.0 | 214 | 210 | 197 | 181 | 163 | 144 | 120 | |
| CKR2-25 | 3.0 | 4.0 | 225 | 219 | 205 | 189 | 170 | 151 | 127 | |
| CKR2-26 | 3.0 | 4.0 | 234 | 228 | 214 | 198 | 178 | 158 | 132 | |

安装图

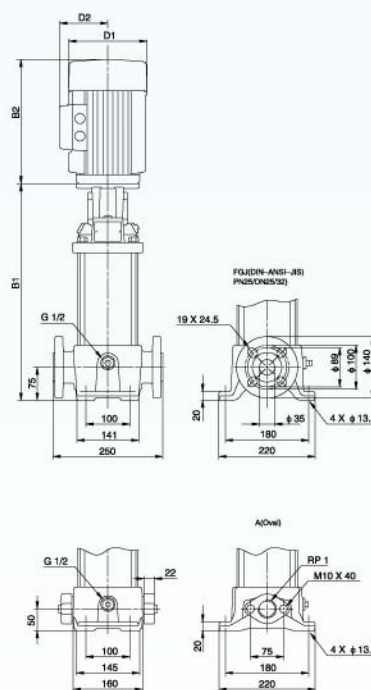

尺寸和重量

| 泵型号 | 尺寸 [mm] | | | | 净重 [kg] | | | |
|---------|---------|-------|--------|-------|---------|-----|--------|--------|
| | PJE/CA | | DIN 法兰 | | D1 | D2 | PJE/CA | DIN 法兰 |
| | B1 | B1+B2 | B1 | B1+B2 | | | | |
| CKR2-2 | 257 | 448 | 282 | 473 | 141 | 109 | 16 | 20 |
| CKR2-3 | 257 | 448 | 282 | 473 | 141 | 109 | 16 | 20 |
| CKR2-4 | 275 | 466 | 300 | 491 | 141 | 109 | 17 | 21 |
| CKR2-5 | 293 | 657 | 318 | 682 | 141 | 109 | 17 | 21 |
| CKR2-6 | 317 | 548 | 342 | 573 | 141 | 109 | 18 | 22 |
| CKR2-7 | 335 | 566 | 360 | 591 | 141 | 109 | 19 | 21 |
| CKR2-8 | 353 | 584 | 378 | 609 | 141 | 109 | 19 | 23 |
| CKR2-9 | 371 | 602 | 396 | 627 | 141 | 109 | 20 | 24 |
| CKR2-10 | 389 | 620 | 414 | 645 | 141 | 109 | 20 | 24 |
| CKR2-11 | 407 | 638 | 332 | 663 | 141 | 109 | 20 | 24 |
| CKR2-12 | 441 | 722 | 466 | 747 | 178 | 110 | 23 | 27 |
| CKR2-13 | 459 | 740 | 484 | 765 | 178 | 110 | 23 | 28 |
| CKR2-14 | 477 | 758 | 502 | 783 | 178 | 110 | 26 | 28 |
| CKR2-15 | 495 | 776 | 520 | 801 | 178 | 110 | 26 | 29 |
| CKR2-16 | 513 | 794 | 538 | 819 | 178 | 110 | 28 | 30 |
| CKR2-17 | 531 | 812 | 556 | 837 | 178 | 110 | 30 | 32 |
| CKR2-18 | 549 | 830 | 574 | 855 | 178 | 110 | 32 | 33 |
| CKR2-19 | 567 | 848 | 592 | 873 | 178 | 110 | 32 | 33 |
| CKR2-20 | 585 | 866 | 610 | 891 | 178 | 110 | 34 | 37 |
| CKR2-21 | 603 | 884 | 628 | 909 | 178 | 110 | 34 | 38 |
| CKR2-22 | 621 | 902 | 646 | 927 | 178 | 110 | 35 | 39 |
| CKR2-23 | 643 | 978 | 668 | 1002 | 198 | 120 | 36 | 40 |
| CKR2-24 | 661 | 996 | 686 | 1021 | 198 | 120 | 36 | 39 |
| CKR2-25 | 679 | 1014 | 704 | 1039 | 198 | 120 | 37 | 41 |
| CKR2-26 | 697 | 1032 | 722 | 1057 | 198 | 120 | 38 | 41 |



性能曲线

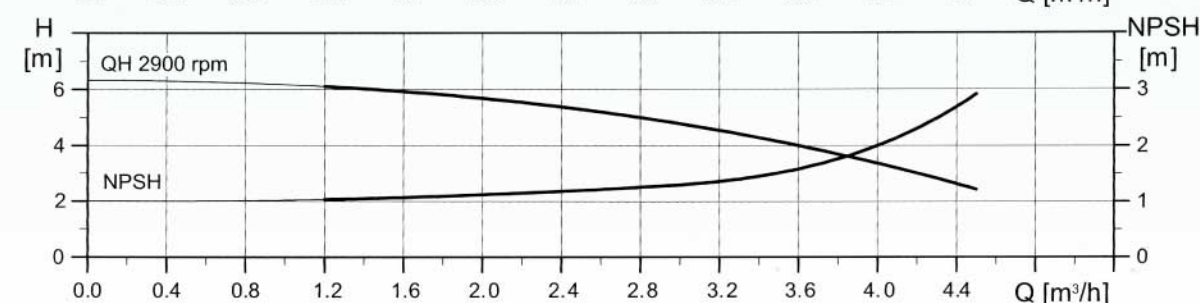
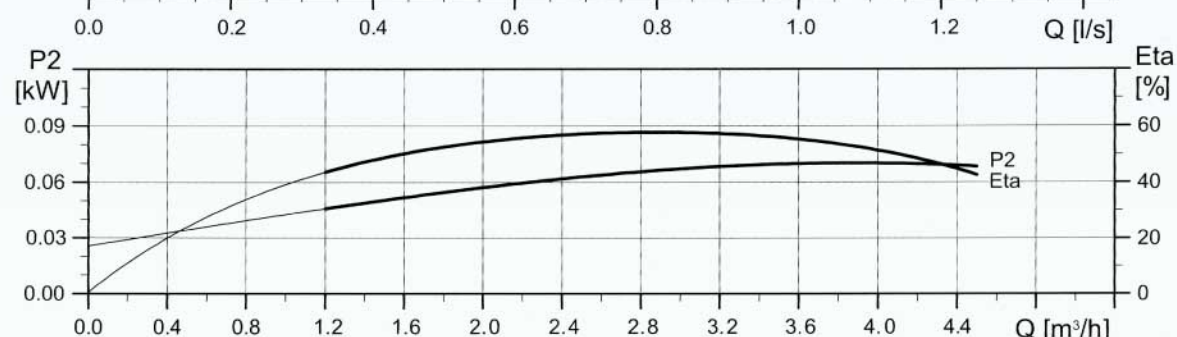
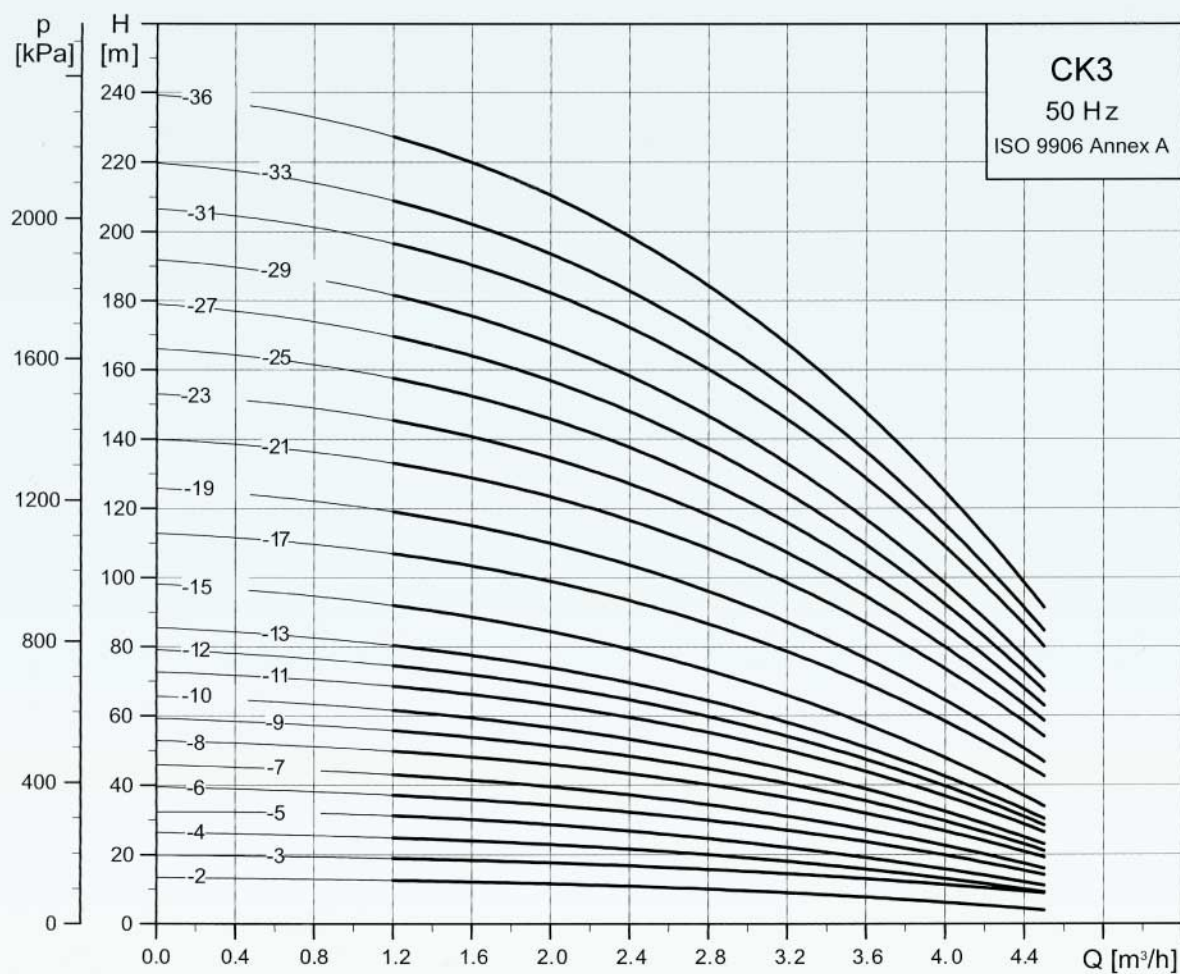

性能表

| 泵型号 | 电机 | | 流量 Q (n≈2900) | | | | | | | | | |
|--------|------|------|---------------|-----|-----|-----|-----|-----|-----|-----|-----|-----|
| | kW | HP | m³/h | 1.2 | 1.6 | 2.0 | 2.4 | 2.8 | 3.2 | 3.6 | 4.0 | 4.4 |
| CK3-2 | 0.37 | 0.50 | 13 | 12 | 11 | 10 | 9 | 8 | 7 | 6 | 5 | |
| CK3-3 | 0.37 | 0.50 | 19 | 18 | 17 | 16 | 15 | 14 | 13 | 12 | 11 | |
| CK3-4 | 0.37 | 0.50 | 25 | 24 | 23 | 22 | 20 | 18 | 16 | 14 | 12 | |
| CK3-5 | 0.37 | 0.50 | 32 | 30 | 28 | 26 | 24 | 22 | 19 | 16 | 13 | |
| CK3-6 | 0.55 | 0.75 | 37 | 36 | 34 | 32 | 30 | 28 | 25 | 20 | 16 | |
| CK3-7 | 0.55 | 0.75 | 44 | 42 | 40 | 37 | 34 | 31 | 27 | 23 | 18 | |
| CK3-8 | 0.75 | 1.0 | 50 | 48 | 46 | 43 | 40 | 37 | 32 | 26 | 21 | |
| CK3-9 | 0.75 | 1.0 | 55 | 53 | 51 | 48 | 45 | 40 | 35 | 30 | 23 | |
| CK3-10 | 0.75 | 1.0 | 62 | 59 | 56 | 53 | 50 | 45 | 39 | 32 | 25 | |
| CK3-11 | 1.1 | 1.5 | 69 | 67 | 65 | 60 | 54 | 50 | 45 | 37 | 29 | |
| CK3-12 | 1.1 | 1.5 | 75 | 72 | 69 | 65 | 60 | 53 | 47 | 40 | 31 | |
| CK3-13 | 1.1 | 1.5 | 80 | 77 | 73 | 70 | 65 | 58 | 52 | 42 | 33 | |
| CK3-15 | 1.1 | 1.5 | 92 | 88 | 85 | 79 | 73 | 67 | 58 | 48 | 37 | |
| CK3-17 | 1.5 | 2.0 | 107 | 104 | 99 | 93 | 86 | 78 | 70 | 58 | 46 | |
| CK3-19 | 1.5 | 2.0 | 118 | 115 | 110 | 105 | 95 | 87 | 76 | 65 | 51 | |
| CK3-21 | 2.2 | 3.0 | 133 | 129 | 125 | 115 | 108 | 98 | 88 | 73 | 58 | |
| CK3-23 | 2.2 | 3.0 | 145 | 140 | 134 | 127 | 118 | 108 | 94 | 80 | 63 | |
| CK3-25 | 2.2 | 3.0 | 157 | 152 | 147 | 138 | 127 | 115 | 102 | 86 | 68 | |
| CK3-27 | 2.2 | 3.0 | 170 | 165 | 157 | 149 | 136 | 125 | 109 | 92 | 73 | |
| CK3-29 | 2.2 | 3.0 | 182 | 175 | 167 | 158 | 147 | 133 | 116 | 98 | 78 | |
| CK3-31 | 3.0 | 4.0 | 196 | 190 | 182 | 173 | 160 | 146 | 130 | 110 | 86 | |
| CK3-33 | 3.0 | 4.0 | 209 | 203 | 194 | 183 | 170 | 154 | 135 | 115 | 92 | |
| CK3-36 | 3.0 | 4.0 | 228 | 220 | 210 | 198 | 185 | 167 | 148 | 125 | 98 | |

安装图

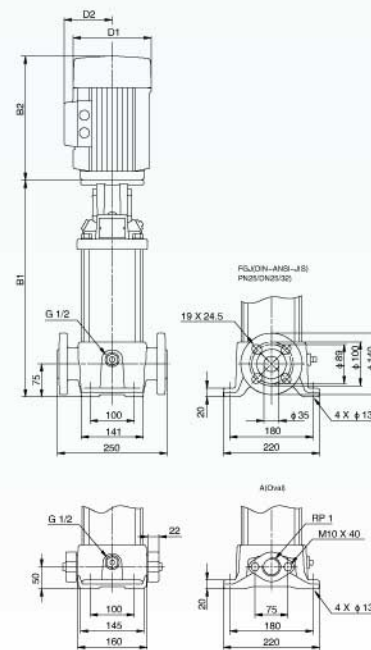

尺寸和重量

| 泵型号 | 尺寸 [mm] | | | | 净重 [kg] | |
|--------|---------|--------|-----|------|---------|--------|
| | 椭圆法兰 | DIN 法兰 | D1 | D2 | 椭圆法兰 | DIN 法兰 |
| CK3-2 | 254 | 445 | 279 | 470 | 18 | 23 |
| CK3-3 | 254 | 445 | 279 | 470 | 18 | 23 |
| CK3-4 | 272 | 463 | 297 | 488 | 19 | 23 |
| CK3-5 | 290 | 481 | 315 | 506 | 19 | 24 |
| CK3-6 | 308 | 499 | 333 | 524 | 20 | 25 |
| CK3-7 | 326 | 517 | 351 | 542 | 21 | 25 |
| CK3-8 | 350 | 581 | 375 | 606 | 23 | 27 |
| CK3-9 | 368 | 599 | 393 | 624 | 23 | 28 |
| CK3-10 | 386 | 617 | 411 | 642 | 24 | 28 |
| CK3-11 | 404 | 635 | 429 | 660 | 26 | 31 |
| CK3-12 | 422 | 653 | 447 | 678 | 26 | 31 |
| CK3-13 | 440 | 671 | 465 | 696 | 27 | 31 |
| CK3-15 | 476 | 707 | 501 | 732 | 28 | 32 |
| CK3-17 | 528 | 809 | 553 | 834 | 36 | 40 |
| CK3-19 | 564 | 845 | 589 | 870 | 37 | 41 |
| CK3-21 | 600 | 921 | 625 | 946 | 38 | 42 |
| CK3-23 | 636 | 957 | 661 | 982 | 39 | 43 |
| CK3-25 | - | - | 697 | 1018 | - | 44 |
| CK3-27 | - | - | 733 | 1054 | - | 45 |
| CK3-29 | - | - | 769 | 1090 | - | 46 |
| CK3-31 | - | - | 809 | 1144 | - | 51 |
| CK3-33 | - | - | 845 | 1180 | - | 51 |
| CK3-36 | - | - | 899 | 1234 | - | 53 |



性能曲线

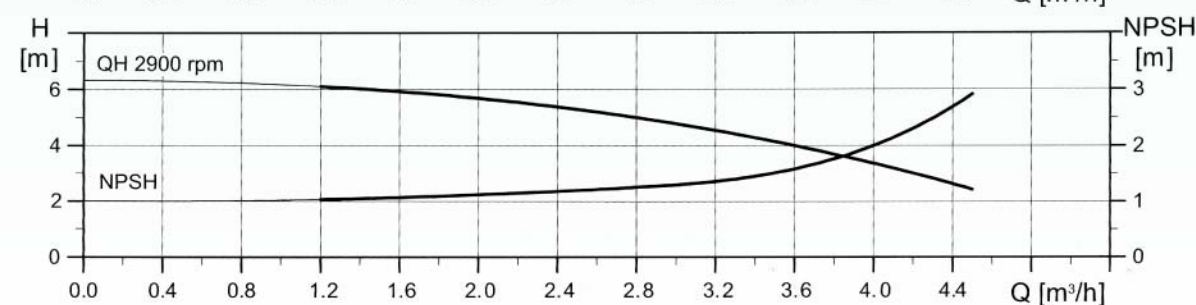
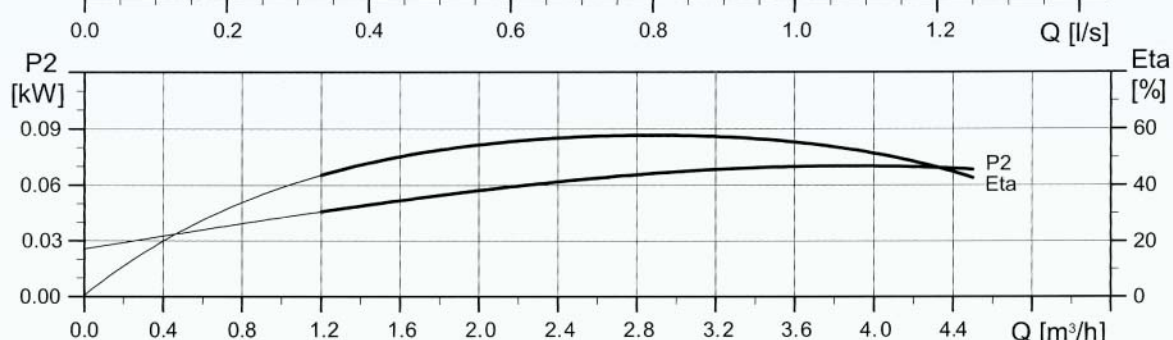
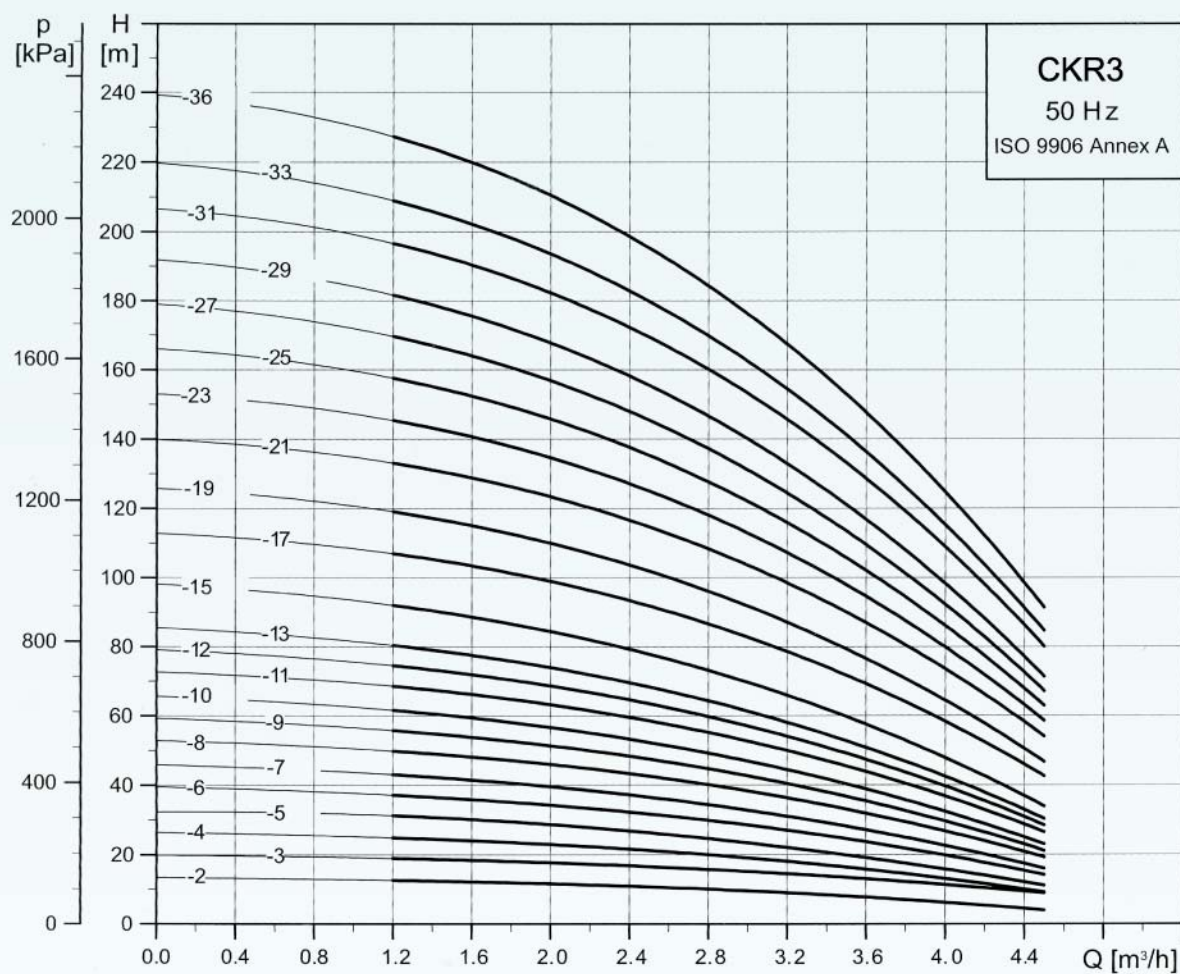

性能表

| 泵型号 | 电机 | | 流量 Q (n≈2900) | | | | | | | | | |
|---------|------|------|---------------|-----|-----|-----|-----|-----|-----|-----|-----|-----|
| | kW | HP | m³/h | 1.2 | 1.6 | 2.0 | 2.4 | 2.8 | 3.2 | 3.6 | 4.0 | 4.4 |
| CKR3-2 | 0.37 | 0.50 | 13 | 12 | 11 | 10 | 9 | 8 | 7 | 6 | 5 | |
| CKR3-3 | 0.37 | 0.50 | 19 | 18 | 17 | 16 | 15 | 14 | 13 | 12 | 11 | |
| CKR3-4 | 0.37 | 0.50 | 25 | 24 | 23 | 22 | 20 | 18 | 16 | 14 | 12 | |
| CKR3-5 | 0.37 | 0.50 | 32 | 30 | 28 | 26 | 24 | 22 | 19 | 16 | 13 | |
| CKR3-6 | 0.55 | 0.75 | 37 | 36 | 34 | 32 | 30 | 28 | 25 | 20 | 16 | |
| CKR3-7 | 0.55 | 0.75 | 44 | 42 | 40 | 37 | 34 | 31 | 27 | 23 | 18 | |
| CKR3-8 | 0.75 | 1.0 | 50 | 48 | 46 | 43 | 40 | 37 | 32 | 26 | 21 | |
| CKR3-9 | 0.75 | 1.0 | 55 | 53 | 51 | 48 | 45 | 40 | 35 | 30 | 23 | |
| CKR3-10 | 0.75 | 1.0 | 62 | 59 | 56 | 53 | 50 | 45 | 39 | 32 | 25 | |
| CKR3-11 | 1.1 | 1.5 | 69 | 67 | 65 | 60 | 54 | 50 | 45 | 37 | 29 | |
| CKR3-12 | 1.1 | 1.5 | 75 | 72 | 69 | 65 | 60 | 53 | 47 | 40 | 31 | |
| CKR3-13 | 1.1 | 1.5 | 80 | 77 | 73 | 70 | 65 | 58 | 52 | 42 | 33 | |
| CKR3-15 | 1.1 | 1.5 | 92 | 88 | 85 | 79 | 73 | 67 | 58 | 48 | 37 | |
| CKR3-17 | 1.5 | 2.0 | 107 | 104 | 99 | 93 | 86 | 78 | 70 | 58 | 46 | |
| CKR3-19 | 1.5 | 2.0 | 118 | 115 | 110 | 105 | 95 | 87 | 76 | 65 | 51 | |
| CKR3-21 | 2.2 | 3.0 | 133 | 129 | 125 | 115 | 108 | 98 | 88 | 73 | 58 | |
| CKR3-23 | 2.2 | 3.0 | 145 | 140 | 134 | 127 | 118 | 108 | 94 | 80 | 63 | |
| CKR2-25 | 2.2 | 3.0 | 157 | 152 | 147 | 138 | 127 | 115 | 102 | 86 | 68 | |
| CKR2-27 | 2.2 | 3.0 | 170 | 165 | 157 | 149 | 136 | 125 | 109 | 92 | 73 | |
| CKR2-29 | 2.2 | 3.0 | 182 | 175 | 167 | 158 | 147 | 133 | 116 | 98 | 78 | |
| CKR2-31 | 3.0 | 4.0 | 196 | 190 | 182 | 173 | 160 | 146 | 130 | 110 | 86 | |
| CKR2-33 | 3.0 | 4.0 | 209 | 203 | 194 | 183 | 170 | 154 | 135 | 115 | 92 | |
| CKR2-36 | 3.0 | 4.0 | 228 | 220 | 210 | 198 | 185 | 167 | 148 | 125 | 98 | |

安装图

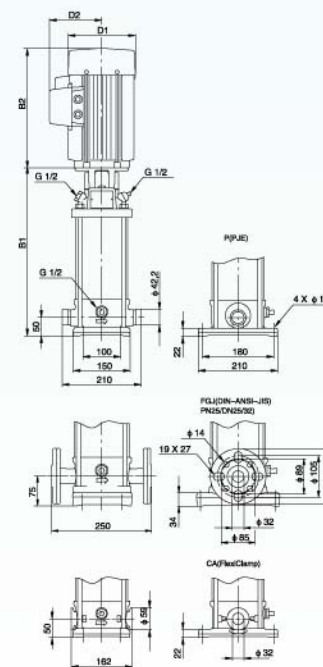

尺寸和重量

| 泵型号 | 尺寸[mm] | | | | 净重[kg] | | | |
|---------|--------|-------|--------|-------|--------|--------|----|----|
| | PJE/CA | | DIN 法兰 | | PJE/CA | DIN 法兰 | | |
| | B1 | B1+B2 | B1 | B1+B2 | D1 | D2 | | |
| CKR3-2 | 257 | 448 | 282 | 473 | 141 | 109 | 16 | 19 |
| CKR3-3 | 257 | 448 | 282 | 473 | 141 | 109 | 16 | 19 |
| CKR3-4 | 275 | 466 | 300 | 491 | 141 | 109 | 17 | 19 |
| CKR3-5 | 293 | 484 | 318 | 509 | 141 | 109 | 17 | 20 |
| CKR3-6 | 311 | 502 | 336 | 527 | 141 | 109 | 18 | 21 |
| CKR3-7 | 329 | 520 | 354 | 545 | 141 | 109 | 19 | 21 |
| CKR3-8 | 353 | 584 | 378 | 609 | 141 | 109 | 21 | 24 |
| CKR3-9 | 371 | 602 | 396 | 627 | 141 | 109 | 22 | 24 |
| CKR3-10 | 389 | 620 | 414 | 645 | 141 | 109 | 22 | 25 |
| CKR3-11 | 407 | 638 | 432 | 663 | 141 | 109 | 25 | 27 |
| CKR3-12 | 425 | 656 | 450 | 681 | 141 | 109 | 25 | 28 |
| CKR3-13 | 443 | 674 | 468 | 699 | 141 | 109 | 26 | 28 |
| CKR3-15 | 479 | 710 | 504 | 735 | 141 | 109 | 26 | 29 |
| CKR3-17 | 531 | 812 | 556 | 837 | 178 | 110 | 34 | 36 |
| CKR3-19 | 567 | 848 | 592 | 873 | 178 | 110 | 34 | 37 |
| CKR3-21 | 603 | 924 | 628 | 949 | 178 | 110 | 36 | 38 |
| CKR3-23 | 639 | 960 | 664 | 985 | 178 | 110 | 37 | 39 |
| CKR3-25 | 675 | 996 | 700 | 1021 | 178 | 110 | 37 | 40 |
| CKR3-27 | 711 | 1032 | 736 | 1057 | 178 | 110 | 38 | 41 |
| CKR3-29 | 747 | 1068 | 772 | 1093 | 178 | 110 | 39 | 42 |
| CKR3-31 | 787 | 1122 | 812 | 1147 | 198 | 120 | 44 | 47 |
| CKR3-33 | 823 | 1158 | 848 | 1183 | 198 | 120 | 45 | 47 |
| CKR3-36 | 877 | 1212 | 902 | 1237 | 198 | 120 | 46 | 49 |



性能曲线

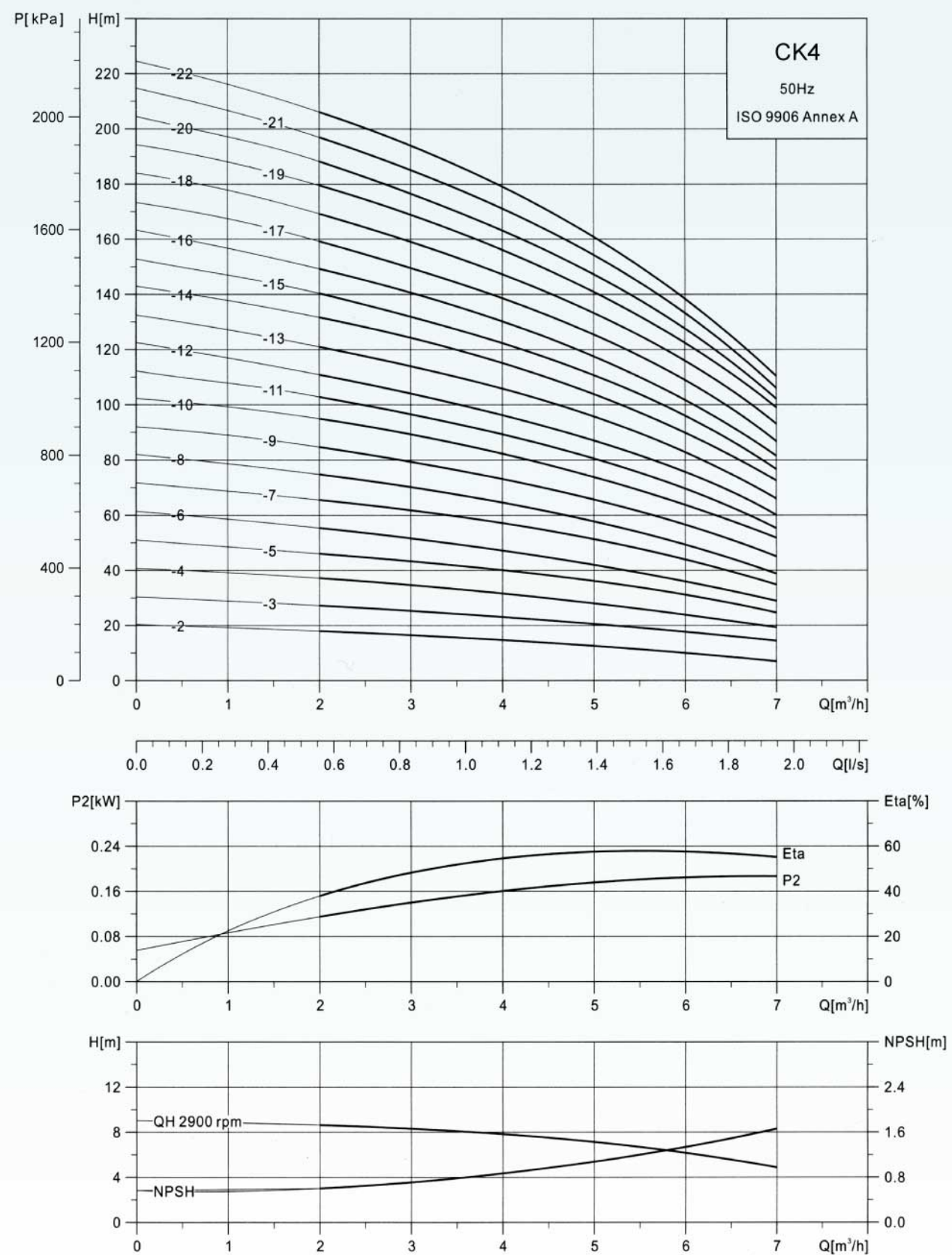

性能表

| 泵型号 | 电机 | | 流量 Q (n≈2900) | | | | | | |
|--------|------|------|---------------|-----|-----|-----|-----|-----|-----|
| | kW | HP | m³/h l/s | 2.0 | 3.0 | 4.0 | 5.0 | 6.0 | 7.0 |
| CK4-2 | 0.37 | 0.50 | 18 | 17 | 15 | 13 | 10 | 8 | |
| CK4-3 | 0.55 | 0.75 | 27 | 26 | 24 | 20 | 18 | 14 | |
| CK4-4 | 0.75 | 1.0 | 36 | 34 | 32 | 27 | 24 | 18 | |
| CK4-5 | 1.1 | 1.5 | 45 | 43 | 40 | 34 | 31 | 23 | |
| CK4-6 | 1.1 | 1.5 | 54 | 52 | 48 | 41 | 37 | 28 | |
| CK4-7 | 1.5 | 2.0 | 63 | 61 | 56 | 48 | 43 | 34 | |
| CK4-8 | 1.5 | 2.0 | 72 | 70 | 64 | 55 | 50 | 38 | |
| CK4-9 | 2.2 | 3.0 | 81 | 78 | 72 | 63 | 56 | 44 | |
| CK4-10 | 2.2 | 3.0 | 90 | 87 | 81 | 71 | 62 | 50 | |
| CK4-11 | 2.2 | 3.0 | 99 | 95 | 88 | 78 | 68 | 53 | |
| CK4-12 | 2.2 | 3.0 | 108 | 104 | 95 | 85 | 75 | 57 | |
| CK4-13 | 3.0 | 4.0 | 117 | 113 | 103 | 93 | 82 | 63 | |
| CK4-14 | 3.0 | 4.0 | 126 | 122 | 112 | 101 | 89 | 69 | |
| CK4-15 | 3.0 | 4.0 | 135 | 131 | 120 | 108 | 95 | 73 | |
| CK4-16 | 3.0 | 4.0 | 144 | 140 | 129 | 115 | 101 | 78 | |
| CK4-17 | 4.0 | 5.5 | 153 | 149 | 137 | 122 | 108 | 83 | |
| CK4-18 | 4.0 | 5.5 | 162 | 158 | 145 | 129 | 115 | 89 | |
| CK4-19 | 4.0 | 5.5 | 171 | 168 | 153 | 137 | 122 | 95 | |
| CK4-20 | 4.0 | 5.5 | 180 | 176 | 161 | 144 | 127 | 99 | |
| CK4-21 | 4.0 | 5.5 | 189 | 184 | 169 | 152 | 132 | 103 | |
| CK4-22 | 4.0 | 5.5 | 198 | 192 | 178 | 160 | 138 | 108 | |

安装图

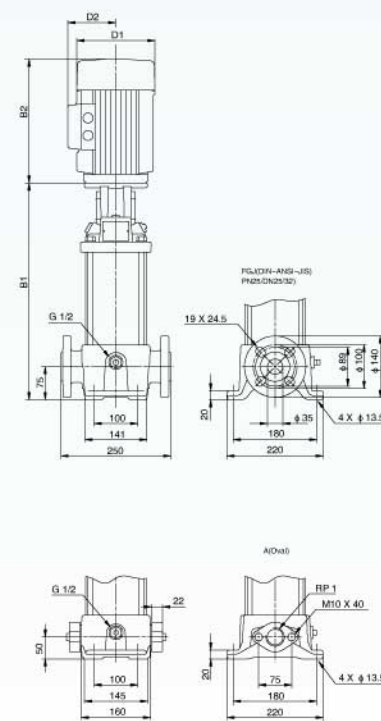

尺寸和重量

| 泵型号 | 尺寸[mm] | | | | 净重[kg] | |
|--------|--------|-------|--------|-------|--------|--------|
| | 椭圆法兰 | | DIN 法兰 | | 椭圆法兰 | DIN 法兰 |
| | B1 | B1+B2 | B1 | B1+B2 | | |
| CK4-2 | 254 | 445 | 279 | 470 | 18 | 23 |
| CK4-3 | 281 | 472 | 306 | 497 | 19 | 24 |
| CK4-4 | 314 | 545 | 339 | 570 | 22 | 27 |
| CK4-5 | 341 | 572 | 366 | 597 | 25 | 30 |
| CK4-6 | 368 | 599 | 393 | 624 | 25 | 30 |
| CK4-7 | 411 | 692 | 436 | 717 | 33 | 38 |
| CK4-8 | 438 | 719 | 463 | 744 | 33 | 38 |
| CK4-9 | 465 | 746 | 490 | 771 | 35 | 40 |
| CK4-10 | 492 | 773 | 517 | 798 | 36 | 41 |
| CK4-11 | 519 | 800 | 544 | 825 | 36 | 41 |
| CK4-12 | 546 | 827 | 571 | 852 | 36 | 41 |
| CK4-13 | 577 | 912 | 602 | 937 | 42 | 47 |
| CK4-14 | 604 | 939 | 629 | 964 | 42 | 47 |
| CK4-15 | 631 | 966 | 656 | 991 | 42 | 47 |
| CK4-16 | 658 | 993 | 683 | 1018 | 43 | 48 |
| CK4-17 | 685 | 1057 | 710 | 1082 | 54 | 59 |
| CK4-18 | 712 | 1084 | 737 | 1109 | 54 | 59 |
| CK4-19 | 739 | 1111 | 764 | 1136 | 55 | 60 |
| CK4-20 | 766 | 1138 | 791 | 1163 | 55 | 60 |
| CK4-21 | 793 | 1165 | 818 | 1190 | 55 | 60 |
| CK4-22 | 820 | 1192 | 845 | 1217 | 56 | 61 |



性能曲线

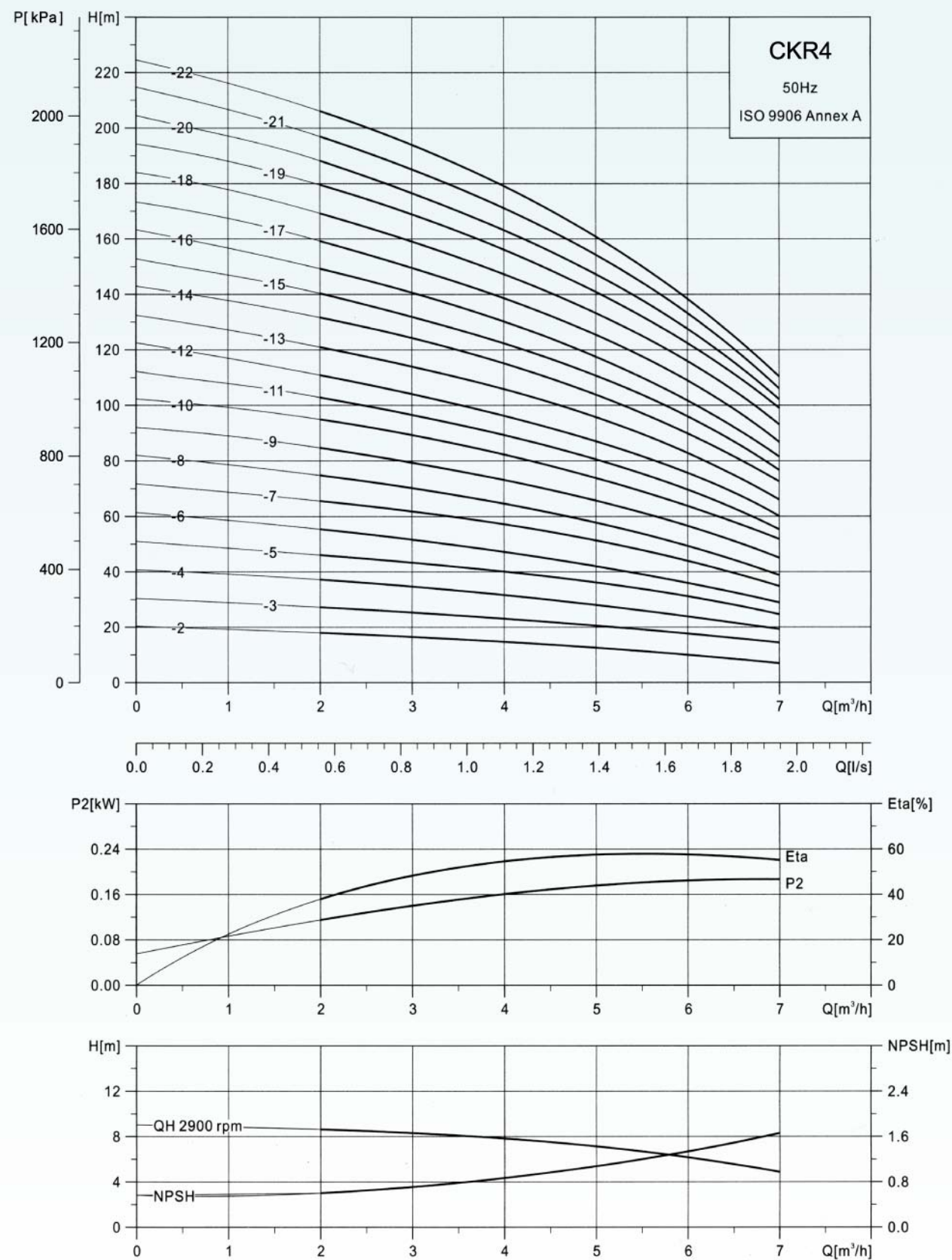

性能表

| 泵型号 | 电机 | | 流量 Q (n≈2900) | | | | | | |
|---------|------|------|---------------|-----|-----|-----|-----|-----|-----|
| | kW | HP | m³/h l/s | 2.0 | 3.0 | 4.0 | 5.0 | 6.0 | 7.0 |
| CKR4-2 | 0.37 | 0.50 | 18 | 17 | 15 | 13 | 10 | 8 | |
| CKR4-3 | 0.55 | 0.75 | 27 | 26 | 24 | 20 | 18 | 14 | |
| CKR4-4 | 0.75 | 1.0 | 36 | 34 | 32 | 27 | 24 | 18 | |
| CKR4-5 | 1.1 | 1.5 | 45 | 43 | 40 | 34 | 31 | 23 | |
| CKR4-6 | 1.1 | 1.5 | 54 | 52 | 48 | 41 | 37 | 28 | |
| CKR4-7 | 1.5 | 2.0 | 63 | 61 | 56 | 48 | 43 | 34 | |
| CKR4-8 | 1.5 | 2.0 | 72 | 70 | 64 | 55 | 50 | 38 | |
| CKR4-9 | 2.2 | 3.0 | 81 | 78 | 72 | 63 | 56 | 44 | |
| CKR4-10 | 2.2 | 3.0 | 90 | 87 | 81 | 71 | 62 | 50 | |
| CKR4-11 | 2.2 | 3.0 | 99 | 95 | 88 | 78 | 68 | 53 | |
| CKR4-12 | 2.2 | 3.0 | 108 | 104 | 95 | 85 | 75 | 57 | |
| CKR4-13 | 3.0 | 4.0 | 117 | 113 | 103 | 93 | 82 | 63 | |
| CKR4-14 | 3.0 | 4.0 | 126 | 122 | 112 | 101 | 89 | 69 | |
| CKR4-15 | 3.0 | 4.0 | 135 | 131 | 120 | 108 | 95 | 73 | |
| CKR4-16 | 3.0 | 4.0 | 144 | 140 | 129 | 115 | 101 | 78 | |
| CKR4-17 | 4.0 | 5.5 | 153 | 149 | 137 | 122 | 108 | 83 | |
| CKR4-18 | 4.0 | 5.5 | 162 | 158 | 145 | 129 | 115 | 89 | |
| CKR4-19 | 4.0 | 5.5 | 171 | 168 | 153 | 137 | 122 | 95 | |
| CKR4-20 | 4.0 | 5.5 | 180 | 176 | 161 | 144 | 127 | 99 | |
| CKR4-21 | 4.0 | 5.5 | 189 | 184 | 169 | 152 | 132 | 103 | |
| CKR4-22 | 4.0 | 5.5 | 198 | 192 | 178 | 160 | 138 | 108 | |

安装图

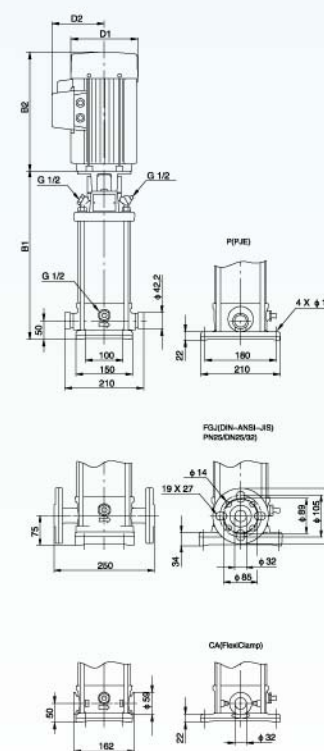

尺寸和重量

| 泵型号 | 尺寸[mm] | | | | | | 净重[kg] | |
|---------|--------|-------|--------|-------|-----|-----|----------|-----------|
| | PJE/CA | | DIN 法兰 | | D1 | D2 | 椭圆 法兰 | DIN 法兰 |
| | B1 | B1+B2 | B1 | B1+B2 | | | | |
| CKR4-2 | 257 | 448 | 282 | 473 | 141 | 109 | 16 | 20 |
| CKR4-3 | 284 | 475 | 309 | 500 | 141 | 109 | 17 | 22 |
| CKR4-4 | 317 | 548 | 342 | 573 | 141 | 109 | 19 | 24 |
| CKR4-5 | 344 | 575 | 369 | 600 | 141 | 109 | 22 | 27 |
| CKR4-6 | 371 | 602 | 396 | 627 | 141 | 109 | 23 | 28 |
| CKR4-7 | 414 | 695 | 439 | 720 | 178 | 110 | 30 | 35 |
| CKR4-8 | 441 | 722 | 466 | 747 | 178 | 110 | 30 | 35 |
| CKR4-9 | 468 | 749 | 493 | 774 | 178 | 110 | 32 | 37 |
| CKR4-10 | 495 | 776 | 520 | 801 | 178 | 110 | 32 | 37 |
| CKR4-11 | 522 | 803 | 547 | 828 | 178 | 110 | 33 | 38 |
| CKR4-12 | 549 | 830 | 574 | 855 | 178 | 110 | 33 | 38 |
| CKR4-13 | 580 | 915 | 605 | 940 | 198 | 120 | 38 | 43 |
| CKR4-14 | 607 | 942 | 632 | 967 | 198 | 120 | 38 | 43 |
| CKR4-15 | 634 | 969 | 659 | 994 | 198 | 120 | 39 | 44 |
| CKR4-16 | 661 | 996 | 686 | 1021 | 198 | 120 | 39 | 44 |
| CKR4-17 | 688 | 1060 | 713 | 1085 | 220 | 134 | 49 | 54 |
| CKR4-18 | 715 | 1087 | 740 | 1112 | 220 | 134 | 49 | 54 |
| CKR4-19 | 742 | 1114 | 767 | 1139 | 220 | 134 | 49 | 54 |
| CKR4-20 | 769 | 1141 | 794 | 1166 | 220 | 134 | 49 | 54 |
| CKR4-21 | 796 | 1168 | 821 | 1193 | 220 | 134 | 50 | 55 |
| CKR4-22 | 823 | 1195 | 848 | 1220 | 220 | 134 | 53 | 57 |



性能曲线

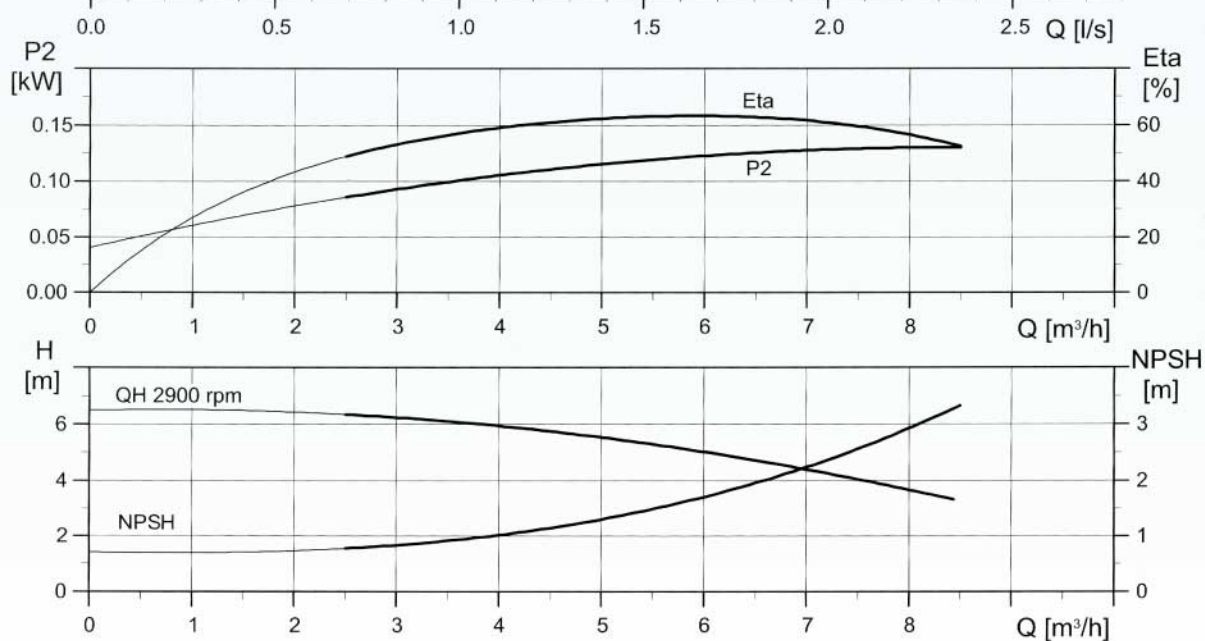
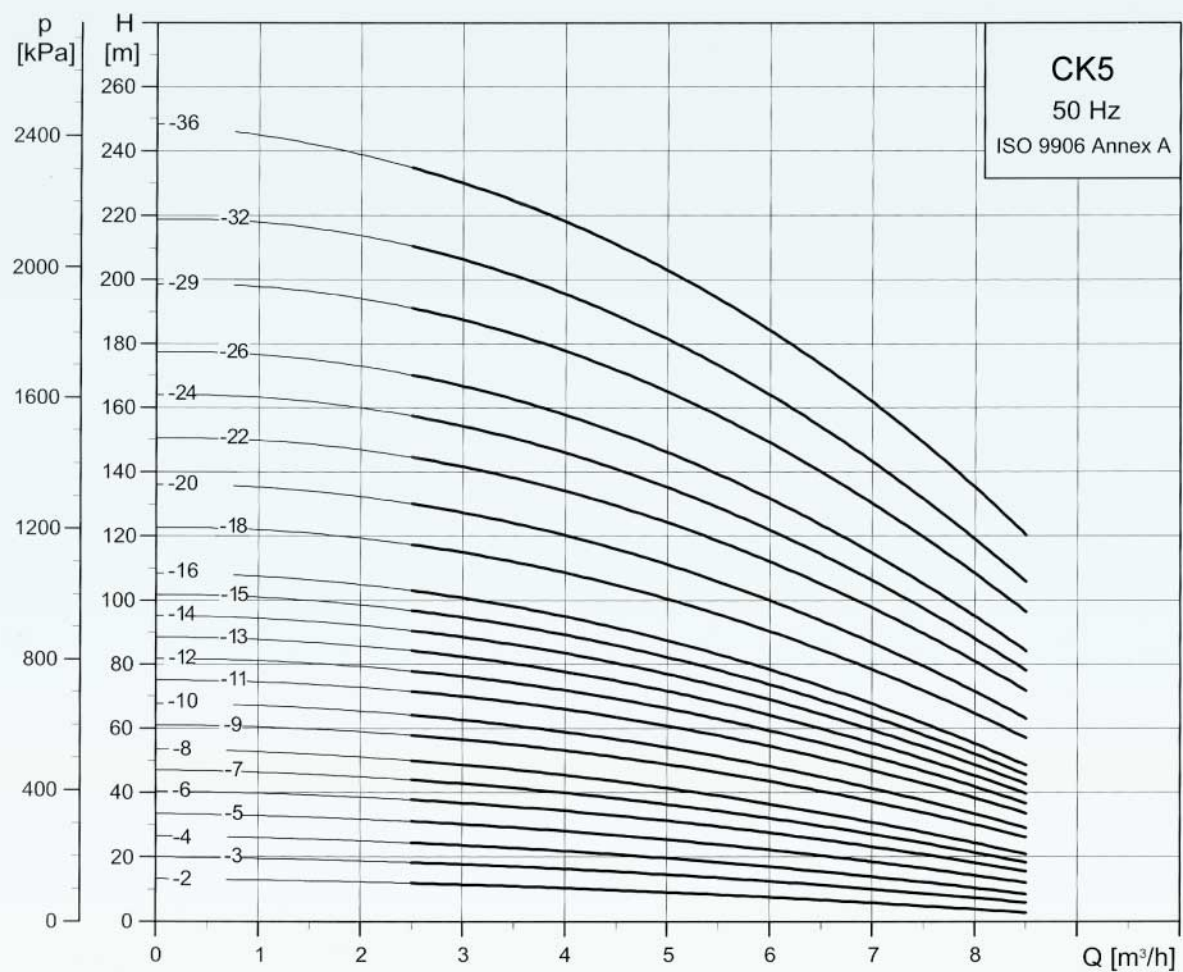

性能表

| 泵型号 | 电机 | | 流量 Q (n≈2900) | | | | | | | |
|--------|------|------|---------------|-----|-----|-----|-----|-----|-----|-----|
| | kW | HP | m³/h l/s | 2.5 | 3.0 | 4.0 | 5.0 | 6.0 | 7.0 | 8.0 |
| CK5-2 | 0.37 | 0.50 | 14 | 13 | 12 | 11 | 9 | 8 | 6 | |
| CK5-3 | 0.55 | 0.75 | 19 | 18 | 17 | 15 | 13 | 11 | 9 | |
| CK5-4 | 0.55 | 0.75 | 25 | 24 | 22 | 20 | 17 | 14 | 12 | |
| CK5-5 | 0.75 | 1.0 | 31 | 30 | 28 | 26 | 22 | 18 | 15 | |
| CK5-6 | 1.1 | 1.5 | 38 | 37 | 35 | 32 | 28 | 23 | 18 | |
| CK5-7 | 1.1 | 1.5 | 44 | 43 | 40 | 36 | 32 | 28 | 22 | |
| CK5-8 | 1.1 | 1.5 | 50 | 48 | 46 | 42 | 35 | 31 | 25 | |
| CK5-9 | 1.5 | 2.0 | 58 | 56 | 54 | 50 | 45 | 37 | 30 | |
| CK5-10 | 1.5 | 2.0 | 64 | 62 | 59 | 54 | 49 | 42 | 34 | |
| CK5-11 | 2.2 | 3.0 | 72 | 70 | 67 | 60 | 54 | 47 | 38 | |
| CK5-12 | 2.2 | 3.0 | 78 | 76 | 72 | 67 | 59 | 51 | 42 | |
| CK5-13 | 2.2 | 3.0 | 84 | 82 | 78 | 73 | 65 | 55 | 46 | |
| CK5-14 | 2.2 | 3.0 | 91 | 89 | 85 | 77 | 69 | 60 | 48 | |
| CK5-15 | 2.2 | 3.0 | 97 | 95 | 90 | 82 | 74 | 64 | 53 | |
| CK5-16 | 2.2 | 3.0 | 103 | 100 | 95 | 88 | 78 | 68 | 54 | |
| CK5-18 | 3.0 | 4.0 | 117 | 114 | 109 | 100 | 90 | 78 | 66 | |
| CK5-20 | 3.0 | 4.0 | 131 | 128 | 120 | 112 | 100 | 88 | 72 | |
| CK5-22 | 4.0 | 5.5 | 145 | 142 | 134 | 125 | 112 | 98 | 81 | |
| CK5-24 | 4.0 | 5.5 | 157 | 154 | 147 | 135 | 122 | 107 | 88 | |
| CK5-26 | 4.0 | 5.5 | 170 | 167 | 158 | 147 | 132 | 115 | 94 | |
| CK5-29 | 4.0 | 5.5 | 182 | 179 | 178 | 166 | 150 | 131 | 110 | |
| CK5-32 | 5.5 | 7.5 | 212 | 208 | 194 | 181 | 164 | 143 | 120 | |
| CK5-36 | 5.5 | 7.5 | 234 | 230 | 218 | 202 | 184 | 162 | 134 | |

安装图

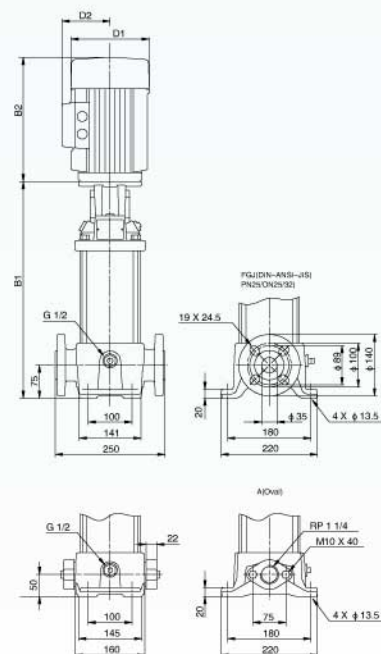

尺寸和重量

| 泵型号 | 尺寸[mm] | | | | 净重[kg] | | | |
|--------|--------|-------|--------|-------|--------|-----|------|--------|
| | 椭圆法兰 | | DIN 法兰 | | D1 | D2 | 椭圆法兰 | DIN 法兰 |
| | B1 | B1+B2 | B1 | B1+B2 | | | | |
| CK5-2 | 254 | 445 | 279 | 470 | 141 | 109 | 18 | 23 |
| CK5-3 | 281 | 472 | 306 | 497 | 141 | 109 | 20 | 24 |
| CK5-4 | 308 | 499 | 333 | 524 | 141 | 109 | 20 | 25 |
| CK5-5 | 341 | 572 | 366 | 597 | 141 | 109 | 22 | 27 |
| CK5-6 | 368 | 599 | 393 | 624 | 141 | 109 | 25 | 30 |
| CK5-7 | 395 | 626 | 420 | 651 | 141 | 109 | 26 | 30 |
| CK5-8 | 422 | 653 | 447 | 678 | 141 | 109 | 26 | 31 |
| CK5-9 | 465 | 746 | 490 | 771 | 178 | 110 | 34 | 38 |
| CK5-10 | 492 | 773 | 517 | 798 | 178 | 110 | 34 | 39 |
| CK5-11 | 519 | 840 | 544 | 865 | 178 | 110 | 36 | 40 |
| CK5-12 | 546 | 867 | 571 | 892 | 178 | 110 | 36 | 41 |
| CK5-13 | 573 | 894 | 598 | 919 | 178 | 110 | 37 | 41 |
| CK5-14 | 600 | 921 | 625 | 946 | 178 | 110 | 37 | 42 |
| CK5-15 | 627 | 948 | 652 | 973 | 178 | 110 | 38 | 43 |
| CK5-16 | 654 | 975 | 679 | 1000 | 178 | 110 | 38 | 43 |
| CK5-18 | 712 | 1047 | 737 | 1072 | 198 | 120 | 44 | 48 |
| CK5-20 | 766 | 1101 | 791 | 1126 | 198 | 120 | 45 | 50 |
| CK5-22 | 820 | 1194 | 845 | 1217 | 220 | 134 | 56 | 62 |
| CK5-24 | - | - | 899 | 1271 | 220 | 134 | - | 63 |
| CK5-26 | - | - | 953 | 1325 | 220 | 134 | - | 64 |
| CK5-29 | - | - | 1034 | 1406 | 220 | 134 | - | 66 |
| CK5-32 | - | - | 1145 | 1536 | 220 | 134 | - | 82 |
| CK5-36 | - | - | 1253 | 1644 | 220 | 134 | - | 84 |



性能曲线

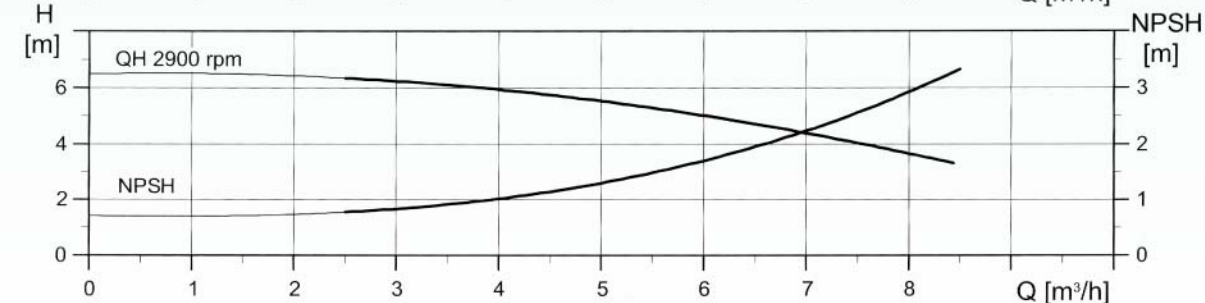
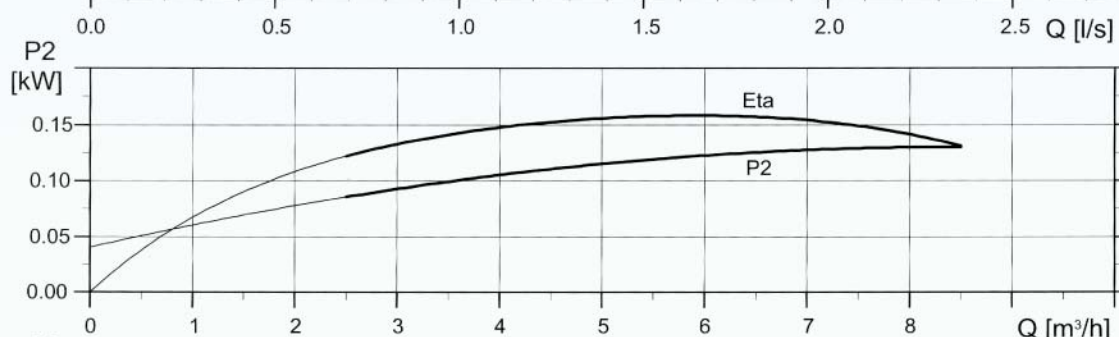
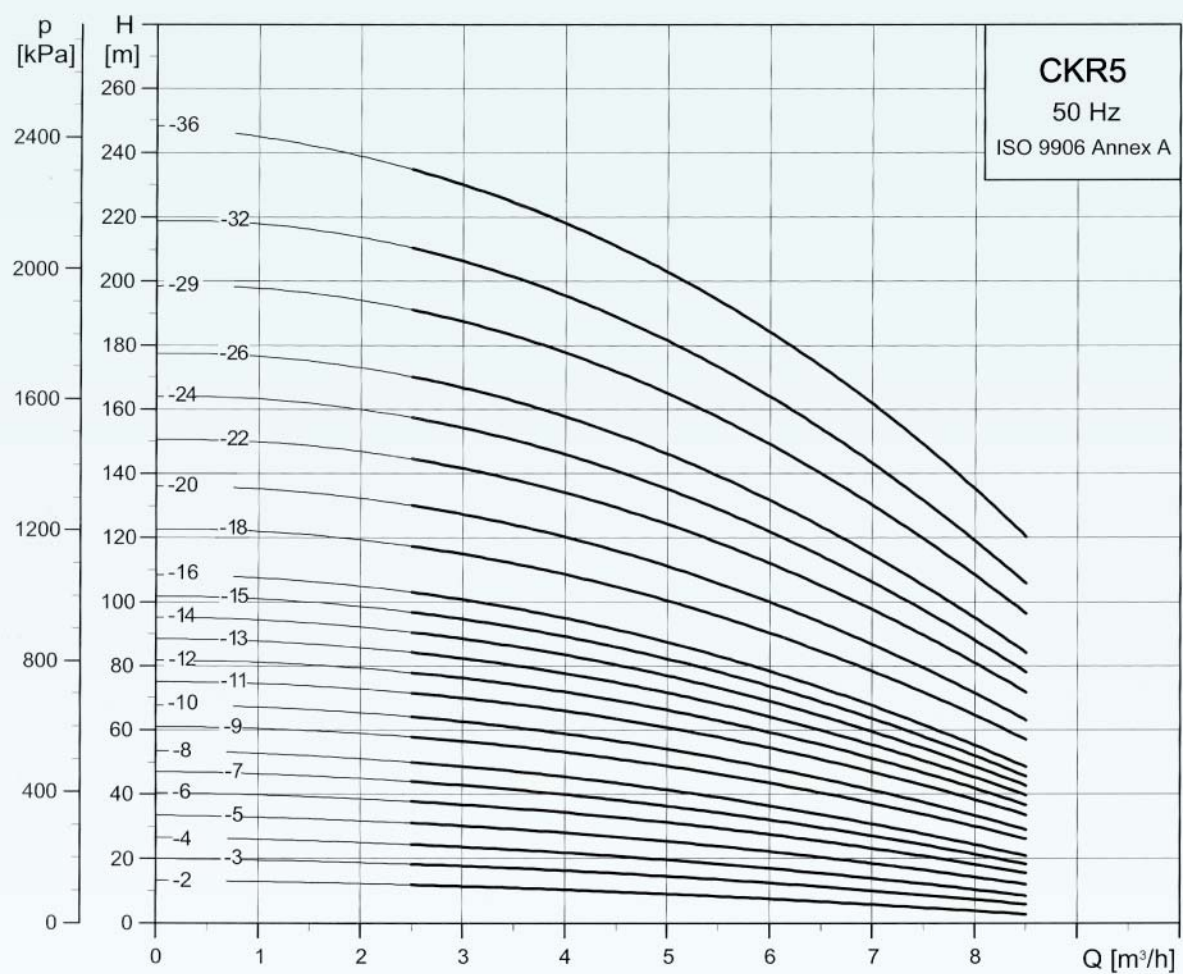

性能表

| 泵型号 | 电机 | | 流量 Q (n≈2900) | | | | | | | |
|---------|------|------|---------------|-----|-----|-----|-----|-----|-----|-----|
| | kW | HP | m³/h l/s | 2.5 | 3.0 | 4.0 | 5.0 | 6.0 | 7.0 | 8.0 |
| CKR5-2 | 0.37 | 0.50 | 14 | 13 | 12 | 11 | 9 | 8 | 6 | |
| CKR5-3 | 0.55 | 0.75 | 19 | 18 | 17 | 15 | 13 | 11 | 9 | |
| CKR5-4 | 0.55 | 0.75 | 25 | 24 | 22 | 20 | 17 | 14 | 12 | |
| CKR5-5 | 0.75 | 1.0 | 31 | 30 | 28 | 26 | 22 | 18 | 15 | |
| CKR5-6 | 1.1 | 1.5 | 38 | 37 | 35 | 32 | 28 | 23 | 18 | |
| CKR5-7 | 1.1 | 1.5 | 44 | 43 | 40 | 36 | 32 | 28 | 22 | |
| CKR5-8 | 1.1 | 1.5 | 50 | 48 | 46 | 42 | 35 | 31 | 25 | |
| CKR5-9 | 1.5 | 2.0 | 58 | 56 | 54 | 50 | 45 | 37 | 30 | |
| CKR5-10 | 1.5 | 2.0 | 64 | 62 | 59 | 54 | 49 | 42 | 34 | |
| CKR5-11 | 2.2 | 3.0 | 72 | 70 | 67 | 60 | 54 | 47 | 38 | |
| CKR5-12 | 2.2 | 3.0 | 78 | 76 | 72 | 67 | 59 | 51 | 42 | |
| CKR5-13 | 2.2 | 3.0 | 84 | 82 | 78 | 73 | 65 | 55 | 46 | |
| CKR5-14 | 2.2 | 3.0 | 91 | 89 | 85 | 77 | 69 | 60 | 48 | |
| CKR5-15 | 2.2 | 3.0 | 97 | 95 | 90 | 82 | 74 | 64 | 53 | |
| CKR5-16 | 2.2 | 3.0 | 103 | 100 | 95 | 88 | 78 | 68 | 54 | |
| CKR5-18 | 3.0 | 4.0 | 117 | 114 | 109 | 100 | 90 | 78 | 66 | |
| CKR5-20 | 3.0 | 4.0 | 131 | 128 | 120 | 112 | 100 | 88 | 72 | |
| CKR5-22 | 4.0 | 5.5 | 145 | 142 | 134 | 125 | 112 | 98 | 81 | |
| CKR5-24 | 4.0 | 5.5 | 157 | 154 | 147 | 135 | 122 | 107 | 88 | |
| CKR5-26 | 4.0 | 5.5 | 170 | 167 | 158 | 147 | 132 | 115 | 94 | |
| CKR5-29 | 4.0 | 5.5 | 182 | 179 | 178 | 166 | 150 | 131 | 110 | |
| CKR5-32 | 5.5 | 7.5 | 212 | 208 | 194 | 181 | 164 | 143 | 120 | |
| CKR5-36 | 5.5 | 7.5 | 234 | 230 | 218 | 202 | 184 | 162 | 134 | |

安装图

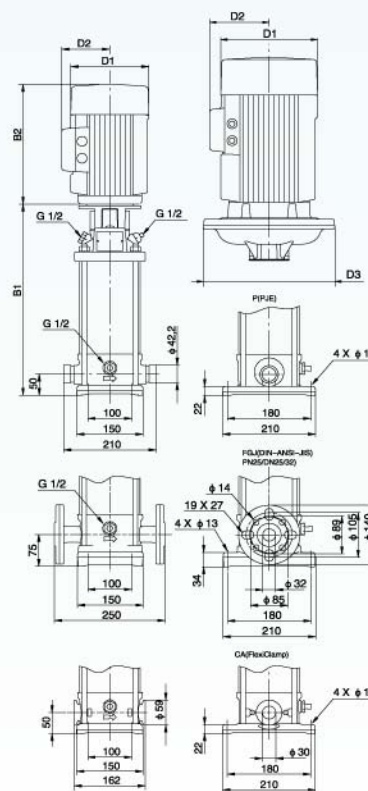

尺寸和重量

| 泵型号 | 尺寸[mm] | | | | | | 净重[kg] | | |
|---------|--------|------|--------|------|-----|-----|--------|--------|--------|
| | PJE/CA | | DIN 法兰 | | D1 | D2 | D3 | PJE/CA | DIN 法兰 |
| CKR5-2 | 257 | 448 | 282 | 473 | 141 | 109 | - | 16 | 21 |
| CKR5-3 | 284 | 475 | 309 | 500 | 141 | 109 | - | 16 | 22 |
| CKR5-4 | 311 | 502 | 336 | 527 | 141 | 109 | - | 18 | 22 |
| CKR5-5 | 344 | 575 | 369 | 600 | 141 | 109 | - | 21 | 25 |
| CKR5-6 | 371 | 302 | 396 | 627 | 141 | 109 | - | 24 | 28 |
| CKR5-7 | 398 | 629 | 423 | 654 | 141 | 109 | - | 24 | 28 |
| CKR5-8 | 425 | 656 | 450 | 681 | 141 | 109 | - | 25 | 29 |
| CKR5-9 | 468 | 749 | 493 | 774 | 178 | 110 | - | 32 | 36 |
| CKR5-10 | 495 | 776 | 520 | 801 | 178 | 110 | - | 32 | 37 |
| CKR5-11 | 522 | 843 | 547 | 868 | 178 | 110 | - | 34 | 38 |
| CKR5-12 | 549 | 870 | 574 | 895 | 178 | 110 | - | 34 | 38 |
| CKR5-13 | 576 | 897 | 601 | 922 | 178 | 110 | - | 35 | 39 |
| CKR5-14 | 603 | 924 | 628 | 949 | 178 | 110 | - | 35 | 40 |
| CKR5-15 | 630 | 951 | 655 | 976 | 178 | 110 | - | 36 | 40 |
| CKR5-16 | 657 | 978 | 682 | 1003 | 178 | 110 | - | 36 | 41 |
| CKR5-18 | 715 | 1050 | 740 | 1075 | 198 | 120 | - | 42 | 46 |
| CKR5-20 | 769 | 1104 | 794 | 1129 | 198 | 120 | - | 43 | 47 |
| CKR5-22 | 823 | 1195 | 848 | 1220 | 220 | 134 | - | 55 | 59 |
| CKR5-24 | 877 | 1249 | 902 | 1274 | 220 | 134 | - | 56 | 61 |
| CKR5-26 | 931 | 1303 | 956 | 1328 | 220 | 134 | - | 58 | 62 |
| CKR5-29 | 1012 | 1384 | 1037 | 1409 | 220 | 134 | - | 59 | 64 |
| CKR5-33 | 1123 | 1514 | 1148 | 1539 | 220 | 134 | 300 | 75 | 79 |
| CKR5-36 | 1231 | 1622 | 1256 | 1647 | 220 | 134 | 300 | 77 | 81 |



性能曲线

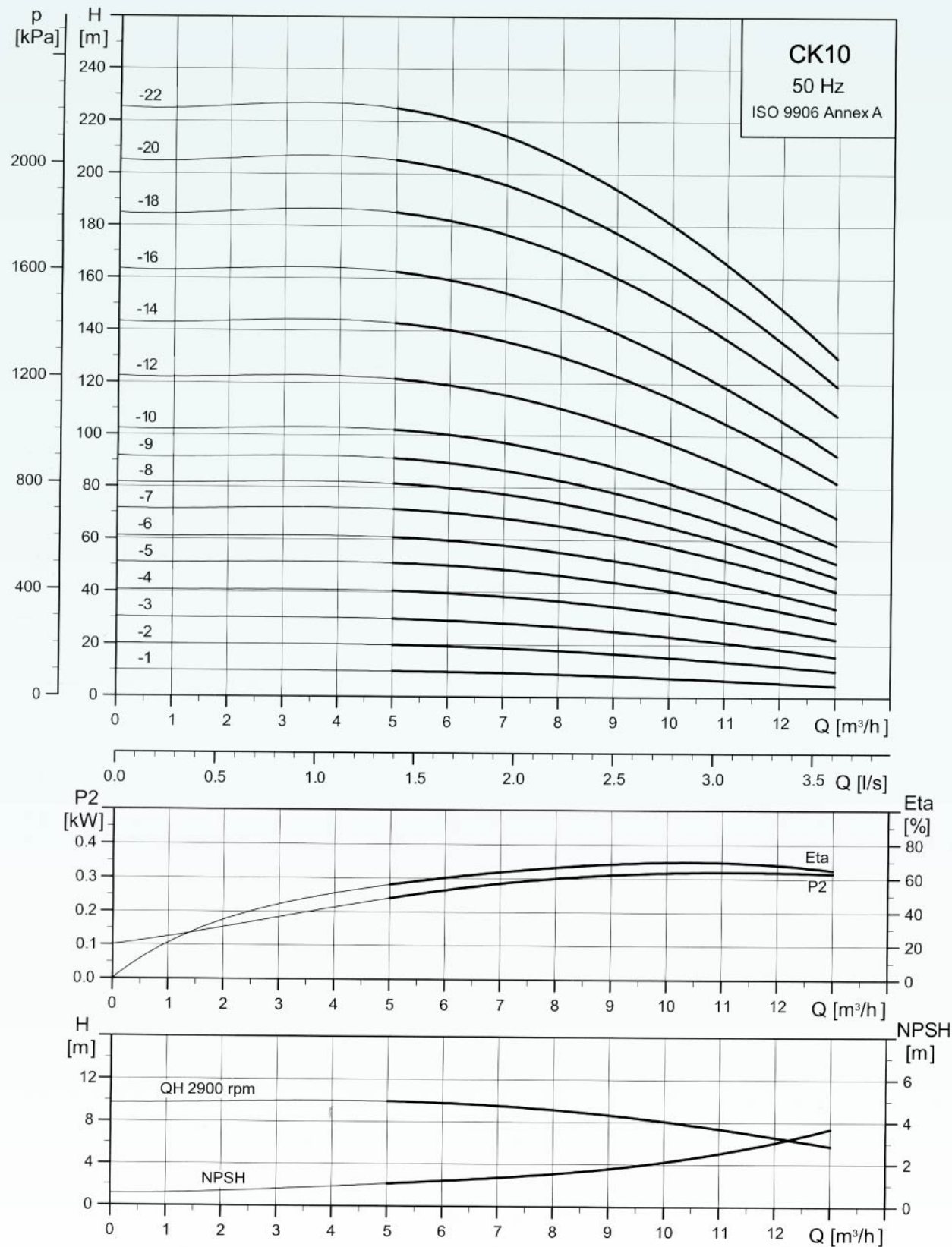

性能表

| 泵型号 | 电机 | | 流量 Q (n≈2900) | | | | | | | | | |
|---------|------|-----|---------------|------|------|------|-----|------|------|------|------|----|
| | kW | HP | m³/h | 5.0 | 6.0 | 7.0 | 8.0 | 9.0 | 10 | 11 | 12 | 13 |
| CK10-1 | 0.37 | 0.5 | 1.39 | 1.67 | 1.94 | 2.22 | 2.5 | 2.78 | 3.06 | 3.33 | 3.61 | |
| CK10-2 | 0.75 | 1.0 | 12 | 11 | 10 | 9 | 8 | 7 | 6 | 5 | 4 | |
| CK10-3 | 1.1 | 1.5 | 20 | 19 | 18 | 17 | 16 | 15 | 14 | 12 | 10 | |
| CK10-4 | 1.5 | 2.0 | 30 | 29 | 28 | 27 | 25 | 23 | 21 | 18 | 16 | |
| CK10-5 | 2.2 | 3.0 | 40 | 39 | 38 | 37 | 35 | 31 | 29 | 26 | 22 | |
| CK10-6 | 2.2 | 3.0 | 50 | 49 | 48 | 47 | 45 | 41 | 37 | 33 | 29 | |
| CK10-7 | 3.0 | 4.0 | 61 | 59 | 58 | 56 | 53 | 49 | 44 | 39 | 34 | |
| CK10-8 | 3.0 | 4.0 | 71 | 70 | 69 | 65 | 62 | 58 | 53 | 47 | 40 | |
| CK10-9 | 3.0 | 4.0 | 81 | 80 | 78 | 75 | 70 | 65 | 59 | 53 | 47 | |
| CK10-10 | 4.0 | 5.5 | 91 | 90 | 88 | 83 | 78 | 73 | 67 | 59 | 51 | |
| CK10-12 | 4.0 | 5.5 | 102 | 100 | 98 | 94 | 89 | 82 | 75 | 67 | 59 | |
| CK10-14 | 5.5 | 7.5 | 122 | 119 | 116 | 111 | 104 | 97 | 89 | 79 | 69 | |
| CK10-16 | 5.5 | 7.5 | 143 | 140 | 137 | 131 | 124 | 115 | 106 | 93 | 82 | |
| CK10-18 | 7.5 | 10 | 163 | 159 | 155 | 148 | 140 | 130 | 119 | 108 | 93 | |
| CK10-20 | 7.5 | 10 | 185 | 182 | 177 | 170 | 160 | 150 | 138 | 123 | 108 | |
| CK10-22 | 7.5 | 10 | 204 | 202 | 195 | 188 | 178 | 166 | 152 | 137 | 119 | |
| | | | 225 | 221 | 215 | 207 | 194 | 180 | 165 | 148 | 130 | |

安装图

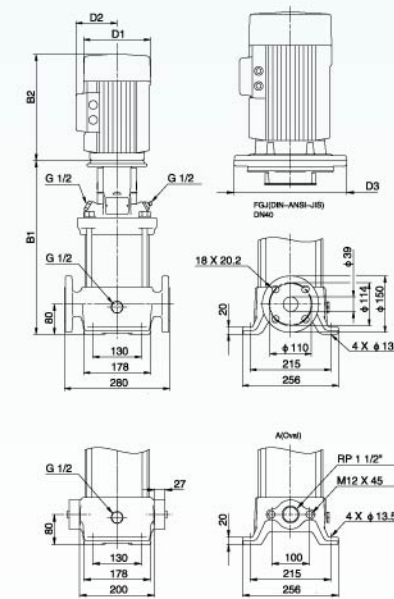

尺寸和重量

| 泵型号 | 尺寸[mm] | | | | | | 净重[kg] | | |
|---------|--------|-------|--------|-------|-----|-----|--------|------|--------|
| | 椭圆法兰 | | DIN 法兰 | | D1 | D2 | D3 | 椭圆法兰 | DIN 法兰 |
| | B1 | B1+B2 | B1 | B1+B2 | | | | | |
| CK10-1 | 343 | 534 | 343 | 534 | 141 | 109 | - | 31 | 34 |
| CK10-2 | 347 | 578 | 347 | 578 | 141 | 109 | - | 34 | 36 |
| CK10-3 | 377 | 608 | 377 | 608 | 141 | 109 | - | 37 | 39 |
| CK10-4 | 423 | 704 | 423 | 704 | 178 | 110 | - | 45 | 47 |
| CK10-5 | 453 | 734 | 453 | 734 | 178 | 110 | - | 46 | 49 |
| CK10-6 | 483 | 764 | 483 | 764 | 178 | 110 | - | 47 | 50 |
| CK10-7 | 518 | 853 | 518 | 853 | 198 | 120 | - | 52 | 55 |
| CK10-8 | 548 | 883 | 548 | 883 | 198 | 120 | - | 53 | 56 |
| CK10-9 | 578 | 913 | 578 | 913 | 198 | 120 | - | 54 | 57 |
| CK10-10 | 608 | 980 | 608 | 980 | 220 | 134 | - | 66 | 69 |
| CK10-12 | 668 | 1040 | 668 | 1040 | 220 | 134 | - | 69 | 71 |
| CK10-14 | 760 | 1151 | 760 | 1151 | 220 | 134 | 300 | 91 | 94 |
| CK10-16 | 820 | 1211 | 820 | 1211 | 220 | 134 | 300 | 93 | 96 |
| CK10-18 | - | - | 880 | 1271 | 220 | 134 | 300 | - | 101 |
| CK10-20 | - | - | 940 | 1331 | 220 | 134 | 300 | - | 103 |
| CK10-22 | - | - | 1000 | 1391 | 220 | 134 | 300 | - | 105 |



性能曲线

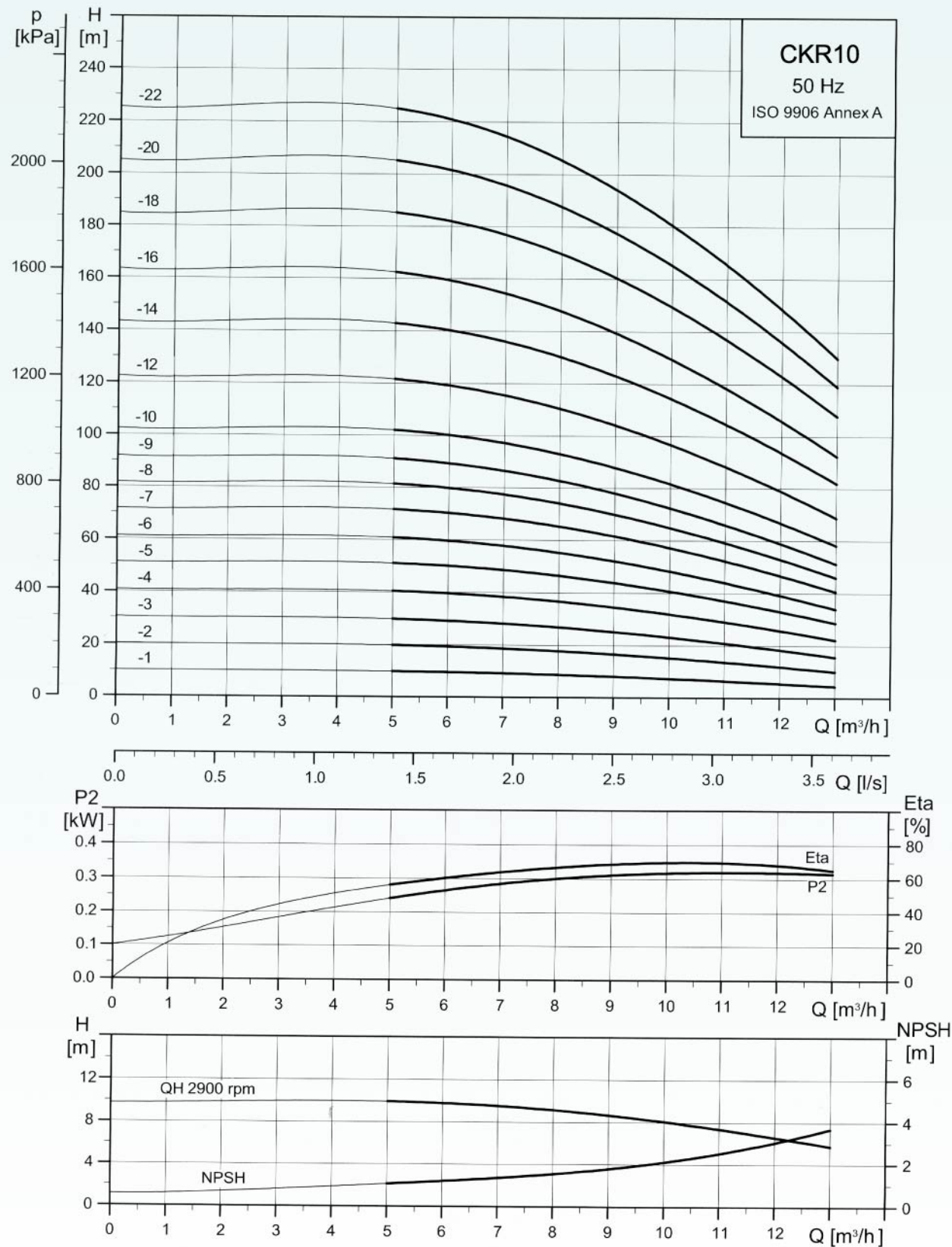

性能表

| 泵型号 | 电机 | | 流量 Q (n≈2900) | | | | | | | | | |
|----------|------|-----|---------------|------|------|------|-----|------|------|------|------|----|
| | kW | HP | m³/h | 5.0 | 6.0 | 7.0 | 8.0 | 9.0 | 10 | 11 | 12 | 13 |
| CKR10-1 | 0.37 | 0.5 | 1.39 | 1.67 | 1.94 | 2.22 | 2.5 | 2.78 | 3.06 | 3.33 | 3.61 | |
| CKR10-2 | 0.75 | 1.0 | 12 | 11 | 10 | 9 | 8 | 7 | 6 | 5 | 4 | |
| CKR10-3 | 1.1 | 1.5 | 20 | 19 | 18 | 17 | 16 | 15 | 14 | 12 | 10 | |
| CKR10-4 | 1.5 | 2.0 | 30 | 29 | 28 | 27 | 25 | 23 | 21 | 18 | 16 | |
| CKR10-5 | 2.2 | 3.0 | 40 | 39 | 38 | 37 | 35 | 31 | 29 | 26 | 22 | |
| CKR10-6 | 2.2 | 3.0 | 50 | 49 | 48 | 47 | 45 | 41 | 37 | 33 | 29 | |
| CKR10-7 | 3.0 | 4.0 | 61 | 59 | 58 | 56 | 53 | 49 | 44 | 39 | 34 | |
| CKR10-8 | 3.0 | 4.0 | 71 | 70 | 69 | 65 | 62 | 58 | 53 | 47 | 40 | |
| CKR10-9 | 3.0 | 4.0 | 81 | 80 | 78 | 75 | 70 | 65 | 59 | 53 | 47 | |
| CKR10-10 | 4.0 | 5.5 | 91 | 90 | 88 | 83 | 78 | 73 | 67 | 59 | 51 | |
| CKR10-12 | 4.0 | 5.5 | 102 | 100 | 98 | 94 | 89 | 82 | 75 | 67 | 59 | |
| CKR10-14 | 5.5 | 7.5 | 122 | 119 | 116 | 111 | 104 | 97 | 89 | 79 | 69 | |
| CKR10-16 | 5.5 | 7.5 | 143 | 140 | 137 | 131 | 124 | 115 | 106 | 93 | 82 | |
| CKR10-18 | 7.5 | 10 | 163 | 159 | 155 | 148 | 140 | 130 | 119 | 108 | 93 | |
| CKR10-20 | 7.5 | 10 | 185 | 182 | 177 | 170 | 160 | 150 | 138 | 123 | 108 | |
| CKR10-22 | 7.5 | 10 | 204 | 202 | 195 | 188 | 178 | 166 | 152 | 137 | 119 | |
| | | | 225 | 221 | 215 | 207 | 194 | 180 | 165 | 148 | 130 | |

安装图

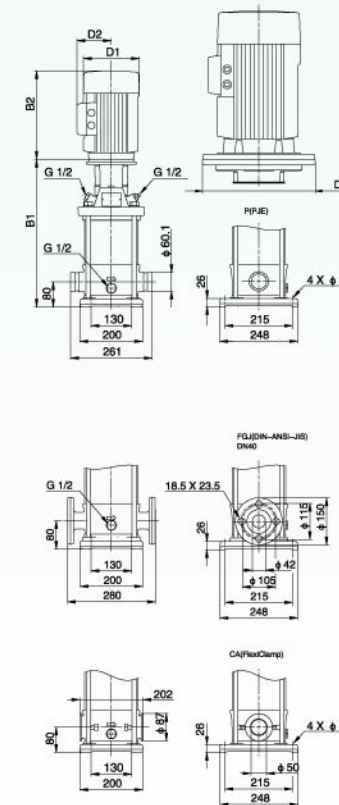

尺寸和重量

| 泵型号 | 尺寸[mm] | | | | | | 净重[kg] | | |
|----------|--------|-------|--------|-------|-----|-----|--------|--------|--------|
| | PJE/CA | | DIN 法兰 | | D1 | D2 | D3 | PJE/CA | DIN 法兰 |
| | B1 | B1+B2 | B1 | B1+B2 | | | | | |
| CKR10-1 | 353 | 544 | 353 | 544 | 141 | 109 | - | 28 | 32 |
| CKR10-2 | 357 | 588 | 357 | 588 | 141 | 109 | - | 31 | 34 |
| CKR10-3 | 387 | 618 | 387 | 618 | 141 | 109 | - | 34 | 38 |
| CKR10-4 | 433 | 714 | 433 | 714 | 178 | 110 | - | 42 | 46 |
| CKR10-5 | 463 | 784 | 463 | 784 | 178 | 110 | - | 44 | 47 |
| CKR10-6 | 493 | 814 | 493 | 814 | 178 | 110 | - | 45 | 48 |
| CKR10-7 | 528 | 863 | 528 | 863 | 198 | 120 | - | 50 | 54 |
| CKR10-8 | 558 | 893 | 558 | 893 | 198 | 120 | - | 51 | 55 |
| CKR10-9 | 588 | 923 | 588 | 923 | 198 | 120 | - | 52 | 56 |
| CKR10-10 | 618 | 990 | 618 | 990 | 220 | 134 | - | 64 | 68 |
| CKR10-12 | 678 | 1050 | 678 | 1050 | 220 | 134 | - | 66 | 70 |
| CKR10-14 | 770 | 1161 | 770 | 1161 | 220 | 134 | 300 | 88 | 92 |
| CKR10-16 | 830 | 1221 | 830 | 1221 | 220 | 134 | 300 | 90 | 94 |
| CKR10-18 | 890 | 1281 | 890 | 1281 | 220 | 134 | 300 | 96 | 99 |
| CKR10-20 | 950 | 1341 | 950 | 1341 | 220 | 134 | 300 | 98 | 101 |
| CKR10-22 | 1010 | 1401 | 1010 | 1401 | 220 | 134 | 300 | 100 | 104 |



性能曲线

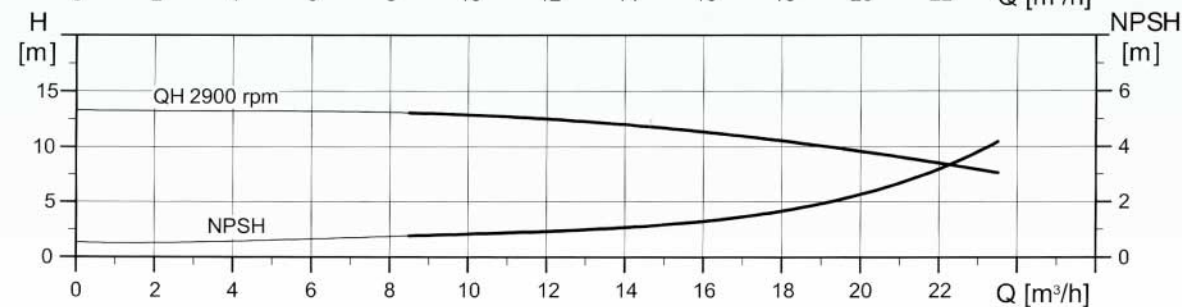
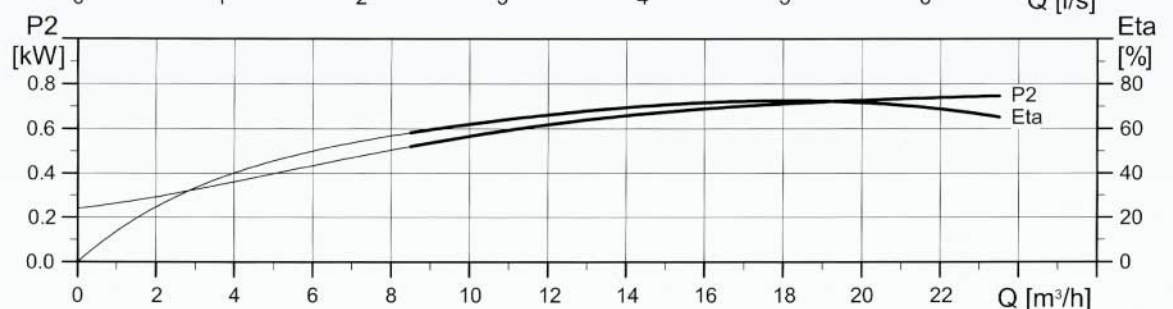
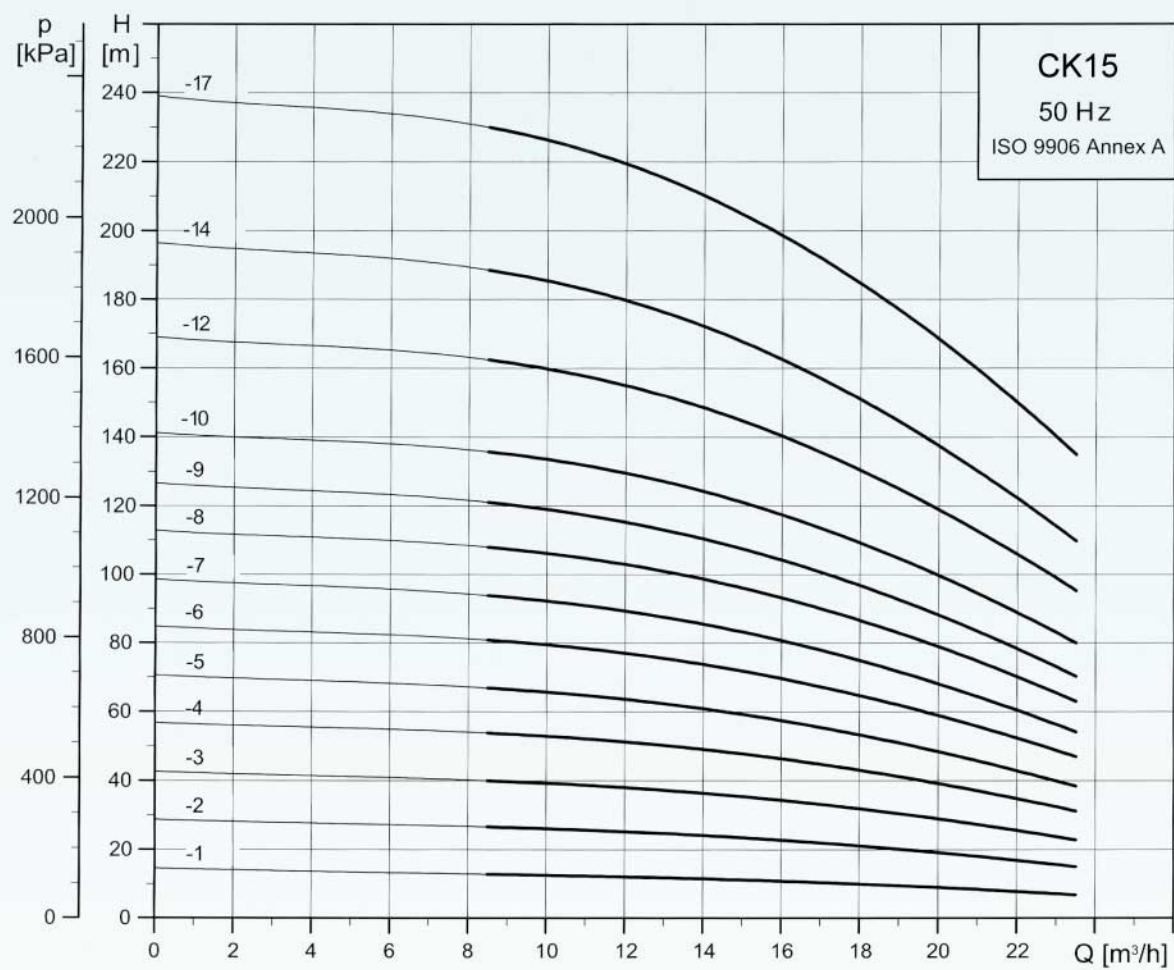

性能表

| 泵型号 | 电机 | | 流量 Q (n≈2900) | | | | | | | | | |
|---------|-----|-----|---------------|-----|-----|-----|-----|-----|-----|-----|-----|------|
| | kW | HP | m³/h | 8.5 | 10 | 12 | 14 | 16 | 18 | 20 | 22 | 23.5 |
| CK15-1 | 1.1 | 1.5 | 13 | 12 | 12 | 11 | 10 | 9 | 8 | 7 | 6 | |
| CK15-2 | 2.2 | 3.0 | 27 | 26 | 25 | 24 | 23 | 21 | 19 | 17 | 15 | |
| CK15-3 | 3.0 | 4.0 | 40 | 39 | 38 | 36 | 34 | 32 | 30 | 27 | 23 | |
| CK15-4 | 4.0 | 5.5 | 53 | 52 | 51 | 49 | 47 | 43 | 39 | 35 | 31 | |
| CK15-5 | 4.0 | 5.5 | 67 | 66 | 64 | 61 | 57 | 53 | 49 | 44 | 39 | |
| CK15-6 | 5.5 | 7.5 | 81 | 79 | 77 | 74 | 70 | 65 | 59 | 53 | 48 | |
| CK15-7 | 5.5 | 7.5 | 94 | 92 | 90 | 86 | 80 | 75 | 68 | 60 | 54 | |
| CK15-8 | 7.5 | 10 | 108 | 106 | 103 | 99 | 93 | 86 | 79 | 70 | 62 | |
| CK15-9 | 7.5 | 10 | 121 | 119 | 115 | 110 | 105 | 97 | 89 | 79 | 70 | |
| CK15-10 | 11 | 15 | 136 | 135 | 130 | 124 | 118 | 110 | 100 | 89 | 80 | |
| CK15-12 | 11 | 15 | 163 | 160 | 155 | 149 | 140 | 130 | 119 | 106 | 94 | |
| CK15-14 | 11 | 15 | 188 | 186 | 180 | 172 | 163 | 152 | 139 | 123 | 110 | |
| CK15-17 | 15 | 20 | 230 | 227 | 220 | 210 | 199 | 185 | 168 | 150 | 136 | |

安装图

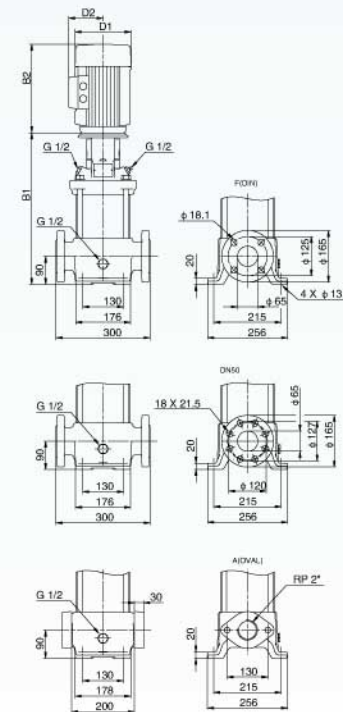

尺寸和重量

| 泵型号 | 尺寸[mm] | | | | | | 净重[kg] | | |
|---------|--------|-------|--------|-------|-----|-----|--------|------|--------|
| | 椭圆法兰 | | DIN 法兰 | | D1 | D2 | D3 | 椭圆法兰 | DIN 法兰 |
| | B1 | B1+B2 | B1 | B1+B2 | | | | | |
| CK15-1 | 400 | 631 | 400 | 631 | 141 | 109 | - | 41 | 42 |
| CK15-2 | 415 | 736 | 415 | 736 | 178 | 110 | - | 49 | 50 |
| CK15-3 | 465 | 800 | 465 | 800 | 198 | 120 | - | 54 | 55 |
| CK15-4 | 510 | 882 | 510 | 882 | 220 | 134 | - | 67 | 68 |
| CK15-5 | 555 | 927 | 555 | 927 | 220 | 134 | - | 68 | 69 |
| CK15-6 | 632 | 1023 | 632 | 1023 | 220 | 134 | 300 | 90 | 91 |
| CK15-7 | 677 | 1068 | 677 | 1068 | 220 | 134 | 300 | 92 | 93 |
| CK15-8 | - | - | 722 | 1113 | 220 | 134 | 300 | - | 97 |
| CK15-9 | - | - | 767 | 1158 | 220 | 134 | 300 | - | 98 |
| CK15-10 | - | - | 889 | 1387 | 334 | 263 | 377 | - | 144 |
| CK15-12 | - | - | 979 | 1477 | 334 | 263 | 377 | - | 145 |
| CK15-14 | - | - | 1069 | 1567 | 334 | 263 | 377 | - | 151 |
| CK15-17 | - | - | 1204 | 1702 | 334 | 263 | 377 | - | 162 |



性能曲线

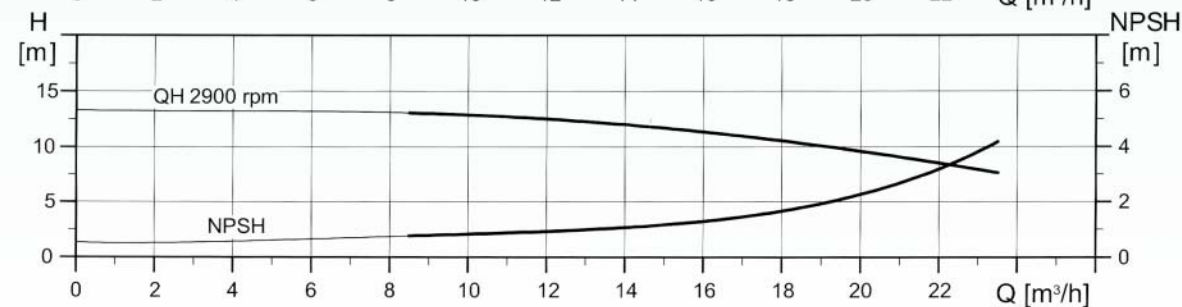
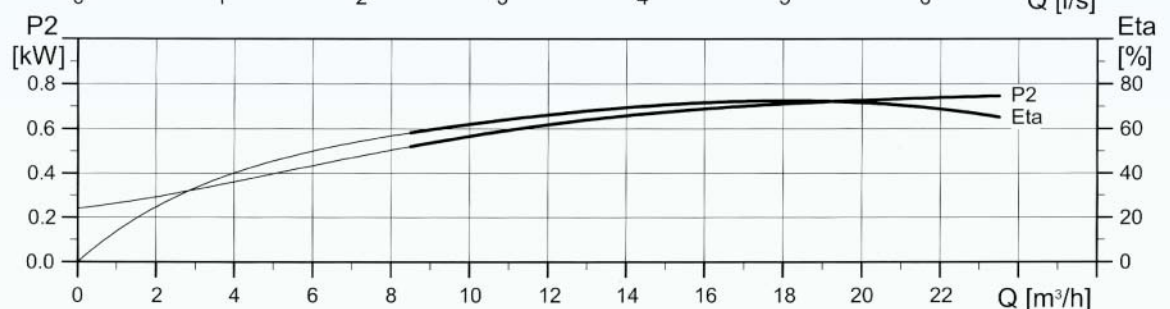
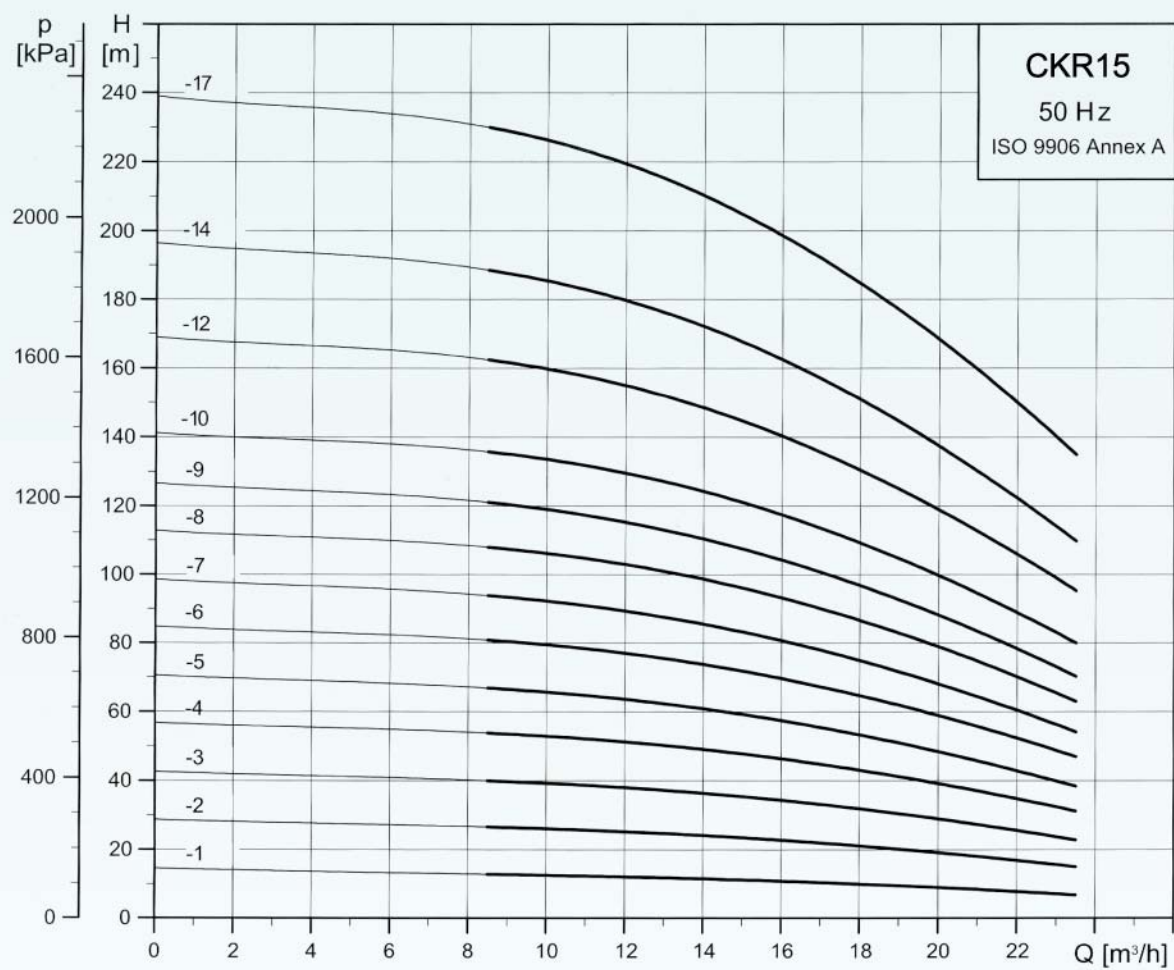

性能表

| 泵型号 | 电机 | | 流量 Q (n≈2900) | | | | | | | | | |
|----------|-----|-----|---------------|-----|-----|-----|-----|-----|-----|-----|-----|------|
| | kW | HP | m³/h | 8.5 | 10 | 12 | 14 | 16 | 18 | 20 | 22 | 23.5 |
| CKR15-1 | 1.1 | 1.5 | 13 | 12 | 12 | 11 | 10 | 9 | 8 | 7 | 6 | |
| CKR15-2 | 2.2 | 3.0 | 27 | 26 | 25 | 24 | 23 | 21 | 19 | 17 | 15 | |
| CKR15-3 | 3.0 | 4.0 | 40 | 39 | 38 | 36 | 34 | 32 | 30 | 27 | 23 | |
| CKR15-4 | 4.0 | 5.5 | 53 | 52 | 51 | 49 | 47 | 43 | 39 | 35 | 31 | |
| CKR15-5 | 4.0 | 5.5 | 67 | 66 | 64 | 61 | 57 | 53 | 49 | 44 | 39 | |
| CKR15-6 | 5.5 | 7.5 | 81 | 79 | 77 | 74 | 70 | 65 | 59 | 53 | 48 | |
| CKR15-7 | 5.5 | 7.5 | 94 | 92 | 90 | 86 | 80 | 75 | 68 | 60 | 54 | |
| CKR15-8 | 7.5 | 10 | 108 | 106 | 103 | 99 | 93 | 86 | 79 | 70 | 62 | |
| CKR15-9 | 7.5 | 10 | 121 | 119 | 115 | 110 | 105 | 97 | 89 | 79 | 70 | |
| CKR15-10 | 11 | 15 | 136 | 135 | 130 | 124 | 118 | 110 | 100 | 89 | 80 | |
| CKR15-12 | 11 | 15 | 163 | 160 | 155 | 149 | 140 | 130 | 119 | 106 | 94 | |
| CKR15-14 | 11 | 15 | 188 | 186 | 180 | 172 | 163 | 152 | 139 | 123 | 110 | |
| CKR15-17 | 15 | 20 | 230 | 227 | 220 | 210 | 199 | 185 | 168 | 150 | 136 | |

安装图

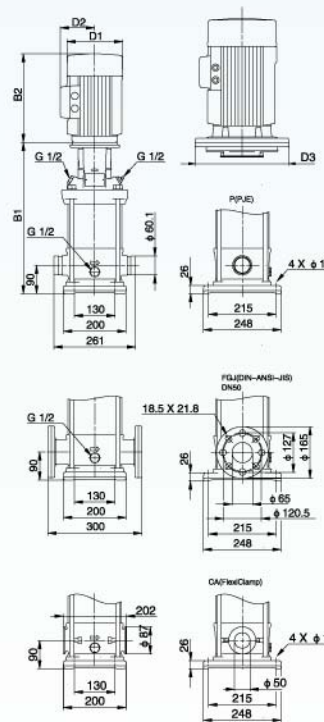

尺寸和重量

| 泵型号 | 尺寸[mm] | | | | | | 净重[kg] | | |
|----------|--------|-------|--------|-------|-----|-----|--------|--------|--------|
| | PJE/CA | | DIN 法兰 | | D1 | D2 | D3 | PJE/CA | DIN 法兰 |
| | B1 | B1+B2 | B1 | B1+B2 | | | | | |
| CKR15-1 | 397 | 628 | 400 | 631 | 141 | 109 | - | 34 | 42 |
| CKR15-2 | 413 | 734 | 415 | 736 | 178 | 110 | - | 42 | 50 |
| CKR15-3 | 463 | 798 | 465 | 800 | 198 | 120 | - | 48 | 55 |
| CKR15-4 | 508 | 880 | 510 | 882 | 220 | 134 | - | 60 | 68 |
| CKR15-5 | 553 | 925 | 555 | 927 | 220 | 134 | - | 62 | 69 |
| CKR15-6 | 630 | 1021 | 632 | 1023 | 220 | 134 | 300 | 83 | 91 |
| CKR15-7 | 675 | 1066 | 677 | 1068 | 220 | 134 | 300 | 85 | 93 |
| CKR15-8 | 720 | 1111 | 722 | 1113 | 220 | 134 | 300 | 89 | 97 |
| CKR15-9 | 765 | 1156 | 767 | 1158 | 220 | 134 | 300 | 90 | 98 |
| CKR15-10 | 887 | 1385 | 889 | 1387 | 334 | 263 | 377 | 136 | 141 |
| CKR15-12 | 977 | 1475 | 979 | 1477 | 334 | 263 | 377 | 140 | 145 |
| CKR15-14 | 1067 | 1565 | 1069 | 1567 | 334 | 263 | 377 | 143 | 148 |
| CKR15-17 | 1202 | 1700 | 1204 | 1702 | 334 | 263 | 377 | 153 | 158 |



性能曲线

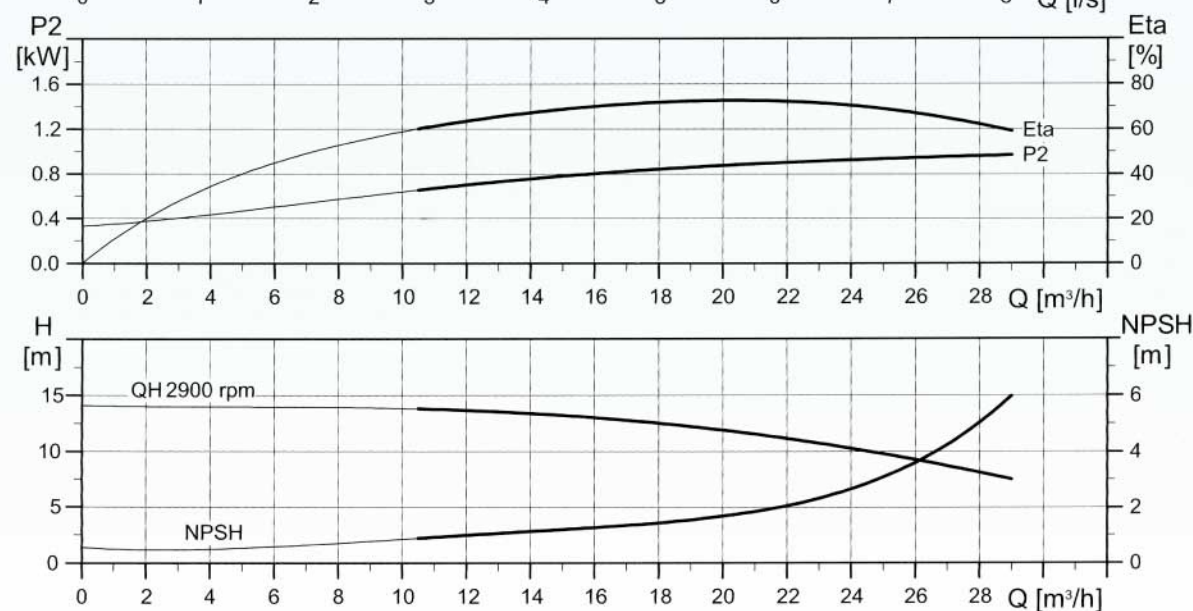
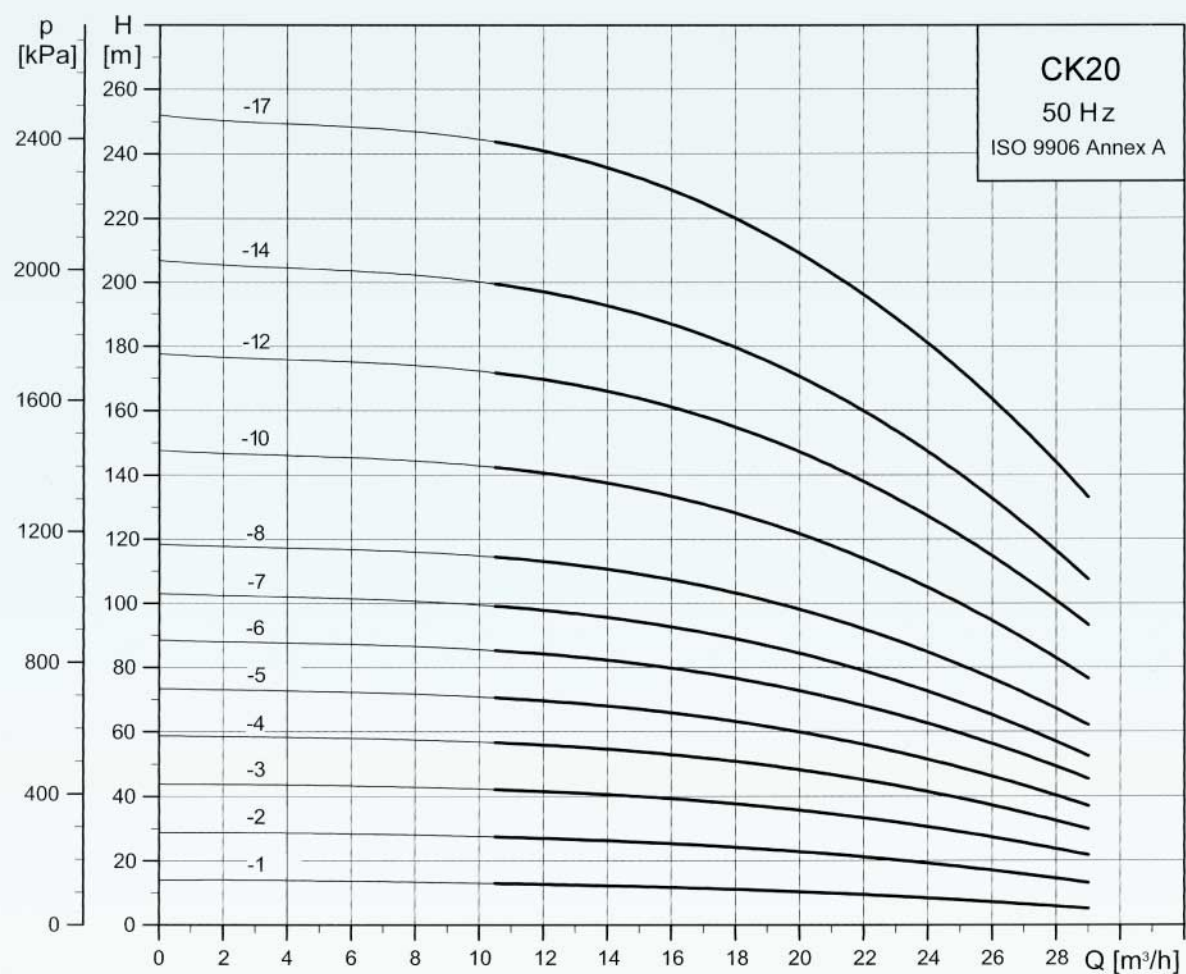

性能表

| 泵型号 | 电机 | | 流量 Q (n≈2900) | | | | | | | | | | | |
|---------|------|-----|---------------|------|-----|-----|-----|-----|-----|-----|-----|-----|-----|----|
| | kW | HP | m/h l/s | 10.5 | 12 | 14 | 16 | 18 | 20 | 22 | 24 | 26 | 28 | 29 |
| CK20-1 | 1.1 | 1.5 | 13 | 13 | 12 | 12 | 11 | 10 | 9 | 8 | 7 | 6 | 5 | |
| CK20-2 | 2.2 | 3.0 | 28 | 27 | 26 | 25 | 24 | 23 | 21 | 19 | 17 | 15 | 13 | |
| CK20-3 | 4.0 | 5.5 | 42 | 41 | 40 | 39 | 38 | 37 | 35 | 32 | 29 | 24 | 21 | |
| CK20-4 | 5.5 | 7.5 | 58 | 56 | 55 | 53 | 50 | 49 | 45 | 41 | 38 | 33 | 30 | |
| CK20-5 | 5.5 | 7.5 | 71 | 70 | 68 | 66 | 63 | 60 | 56 | 50 | 47 | 40 | 38 | |
| CK20-6 | 7.5 | 10 | 85 | 84 | 82 | 80 | 77 | 72 | 68 | 63 | 56 | 50 | 46 | |
| CK20-7 | 7.5 | 10 | 99 | 98 | 96 | 93 | 90 | 85 | 79 | 72 | 66 | 57 | 53 | |
| CK20-8 | 11 | 15 | 114 | 112 | 110 | 108 | 104 | 98 | 92 | 85 | 75 | 68 | 61 | |
| CK20-10 | 11 | 15 | 142 | 140 | 138 | 132 | 128 | 122 | 115 | 105 | 94 | 82 | 76 | |
| CK20-12 | 15 | 20 | 172 | 170 | 165 | 161 | 155 | 148 | 139 | 128 | 114 | 100 | 92 | |
| CK20-14 | 15 | 20 | 200 | 197 | 193 | 188 | 180 | 170 | 160 | 148 | 133 | 117 | 108 | |
| CK20-17 | 18.5 | 25 | 243 | 241 | 235 | 228 | 220 | 210 | 197 | 180 | 162 | 143 | 132 | |

安装图

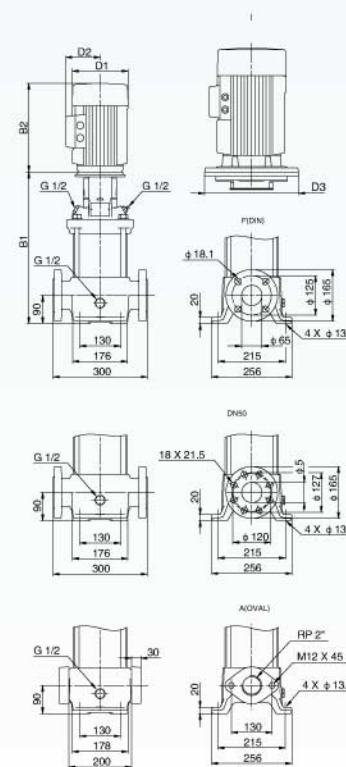

尺寸和重量

| 泵型号 | 尺寸[mm] | | | | | | 净重[kg] | | |
|---------|--------|-------|--------|-------|-----|-----|--------|----------|-----------|
| | 椭圆法兰 | | DIN 法兰 | | D1 | D2 | D3 | 椭圆 法兰 | DIN 法兰 |
| | B1 | B1+B2 | B1 | B1+B2 | | | | | |
| CK20-1 | 400 | 631 | 400 | 631 | 141 | 109 | - | 41 | 42 |
| CK20-2 | 415 | 736 | 415 | 736 | 178 | 110 | - | 49 | 50 |
| CK20-3 | 465 | 837 | 465 | 837 | 220 | 134 | - | 65 | 66 |
| CK20-4 | 542 | 933 | 542 | 933 | 220 | 134 | - | 87 | 88 |
| CK20-5 | 587 | 978 | 587 | 978 | 220 | 134 | - | 89 | 90 |
| CK20-6 | 632 | 1023 | 632 | 1023 | 220 | 134 | 300 | 92 | 93 |
| CK20-7 | 677 | 1068 | 677 | 1068 | 220 | 134 | 300 | 94 | 95 |
| CK20-8 | - | - | 799 | 1297 | 334 | 263 | 377 | - | 141 |
| CK20-10 | - | - | 889 | 1387 | 334 | 263 | 377 | - | 144 |
| CK20-12 | - | - | 979 | 1477 | 334 | 263 | 377 | - | 154 |
| CK20-14 | - | - | 1069 | 1567 | 334 | 263 | 377 | - | 157 |
| CK20-17 | - | - | 1204 | 1702 | 334 | 263 | 377 | - | 177 |



性能曲线

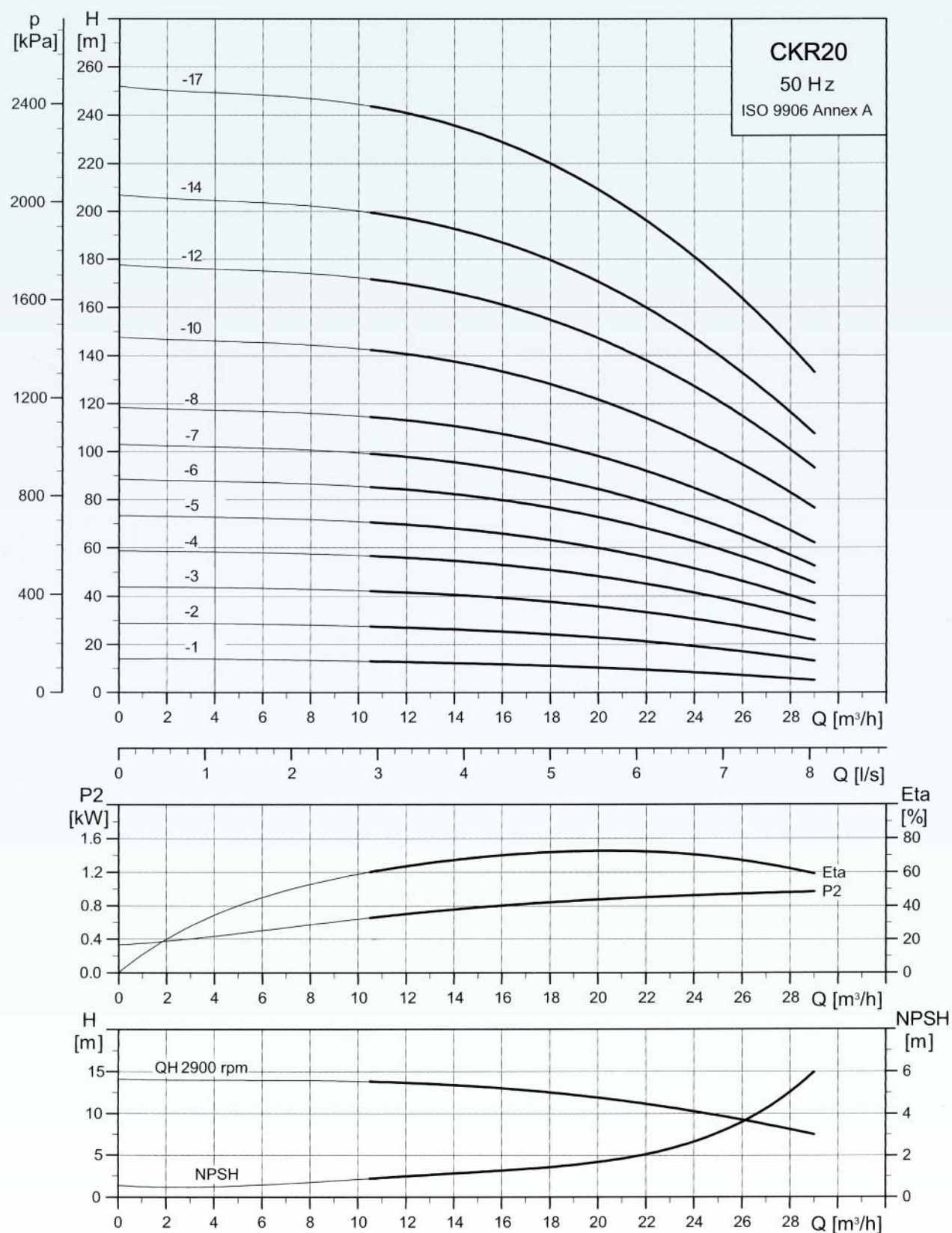

性能表

| 泵型号 | 电机 | | 流量 Q (n≈2900) | | | | | | | | | | | |
|----------|------|-----|---------------|------|-----|-----|-----|-----|-----|-----|-----|-----|-----|----|
| | kW | HP | m/h l/s | 10.5 | 12 | 14 | 16 | 18 | 20 | 22 | 24 | 26 | 28 | 29 |
| CKR20-1 | 1.1 | 1.5 | 13 | 13 | 12 | 12 | 11 | 10 | 9 | 8 | 7 | 6 | 5 | |
| CKR20-2 | 2.2 | 3.0 | 28 | 27 | 26 | 25 | 24 | 23 | 21 | 19 | 17 | 15 | 13 | |
| CKR20-3 | 4.0 | 5.5 | 42 | 41 | 40 | 39 | 38 | 37 | 35 | 32 | 29 | 24 | 21 | |
| CKR20-4 | 5.5 | 7.5 | 58 | 56 | 55 | 53 | 50 | 49 | 45 | 41 | 38 | 33 | 30 | |
| CKR20-5 | 5.5 | 7.5 | 71 | 70 | 68 | 66 | 63 | 60 | 56 | 50 | 47 | 40 | 38 | |
| CKR20-6 | 7.5 | 10 | 85 | 84 | 82 | 80 | 77 | 72 | 68 | 63 | 56 | 50 | 46 | |
| CKR20-7 | 7.5 | 10 | 99 | 98 | 96 | 93 | 90 | 85 | 79 | 72 | 66 | 57 | 53 | |
| CKR20-8 | 11 | 15 | 114 | 112 | 110 | 108 | 104 | 98 | 92 | 85 | 75 | 68 | 61 | |
| CKR20-10 | 11 | 15 | 142 | 140 | 138 | 132 | 128 | 122 | 115 | 105 | 94 | 82 | 76 | |
| CKR20-12 | 15 | 20 | 172 | 170 | 165 | 161 | 155 | 148 | 139 | 128 | 114 | 100 | 92 | |
| CKR20-14 | 15 | 20 | 200 | 197 | 193 | 188 | 180 | 170 | 160 | 148 | 133 | 117 | 108 | |
| CKR20-17 | 18.5 | 25 | 243 | 241 | 235 | 228 | 220 | 210 | 197 | 180 | 162 | 143 | 132 | |

安装图

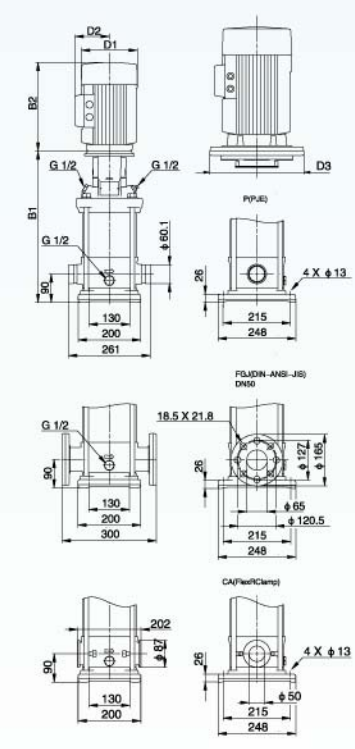

尺寸和重量

| 泵型号 | 尺寸[mm] | | | | | | 净重[kg] | | |
|----------|--------|-------|--------|-------|-----|-----|--------|--------|--------|
| | PJE/CA | | DIN 法兰 | | D1 | D2 | D3 | PJE/CA | DIN 法兰 |
| | B1 | B1+B2 | B1 | B1+B2 | | | | | |
| CKR20-1 | 397 | 628 | 397 | 628 | 141 | 109 | - | 34 | 39 |
| CKR20-2 | 413 | 734 | 413 | 734 | 178 | 110 | - | 42 | 47 |
| CKR20-3 | 463 | 835 | 463 | 835 | 220 | 134 | - | 59 | 63 |
| CKR20-4 | 540 | 931 | 540 | 931 | 220 | 134 | 300 | 80 | 85 |
| CKR20-5 | 585 | 976 | 585 | 976 | 220 | 134 | 300 | 82 | 87 |
| CKR20-6 | 630 | 1021 | 630 | 1021 | 220 | 134 | 300 | 85 | 90 |
| CKR20-7 | 675 | 1066 | 675 | 1066 | 220 | 134 | 300 | 87 | 92 |
| CKR20-8 | 797 | 1295 | 797 | 1296 | 334 | 263 | 377 | 133 | 138 |
| CKR20-10 | 887 | 1385 | 887 | 1386 | 334 | 263 | 377 | 136 | 141 |
| CKR20-12 | 977 | 1475 | 977 | 1455 | 334 | 263 | 377 | 146 | 151 |
| CKR20-14 | 1067 | 1565 | 1067 | 1545 | 334 | 263 | 377 | 149 | 154 |
| CKR20-17 | 1202 | 1700 | 1202 | 1720 | 334 | 263 | 377 | 169 | 173 |



安装、使用注意事项

一、泵的安装

- 1、泵应安装在通风良好且防冰冻的地方。
- 2、吸水管路应尽量短，且应避免产生气穴。
- 3、泵安装时，应注意吸入液面与泵进水口之间的高度差以保证泵在工作时不超过其允许的吸上高度。
- 4、电机应有接地措施，电气装置应保证机组不受缺相，电压不稳和过载的损害。
- 5、泵出口安装压力表以便观察和控制泵的运行情况。

二、泵的使用

1、启动前的准备：

- (1) 启动前认真阅读泵耐压筒上的警示牌，并将泵和现场清理干净。
- (2) 检查地脚螺栓有无松动，法兰螺栓是否拧紧。
- (3) 用工作液体将泵灌满。严禁无介质，未排尽空气运转，导致机械密封、滑动轴承损坏。

2、启动、运行：

- (1) 启动电机，慢慢地打开出口阀，调节到所需工况，流量控制在泵额定流量的0.5-1.3倍范围内，检查出口压力表的波动和泵的振动情况。当确定泵内液体含有空气时，可松开泵头上的调节螺栓，将空气排出。
- (2) 注意泵运转有无杂音，如发现异常应停机检查及时排除。



世博会C片区非洲联合馆

世博会主题馆



世博会国家电网馆

世博会西班牙馆

世博会沙特馆



世博会上海企业联合馆

世博会马德里馆

世博会美国馆



世博会荷兰馆

世博会船舶馆